

# LACCATE LACQUERED - TRAPEZOIDALE

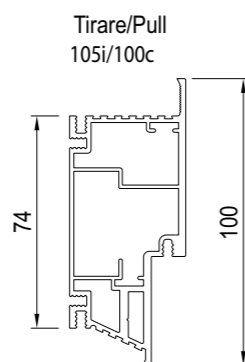
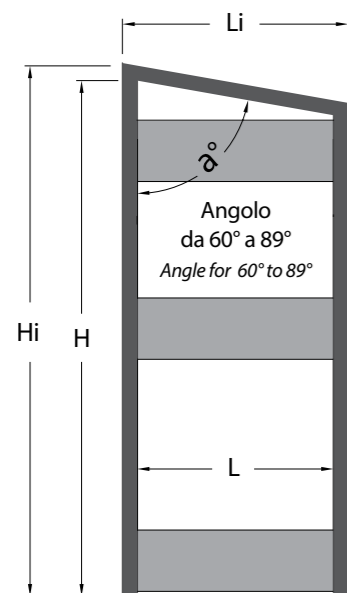

**Legenda Legend**

- L = Larghezza luce Opening Width
- H = Altezza luce Opening Height
- Li = Ingombro in larghezza Overall Width
- Hi = Ingombro in altezza Overall Height
- Pf = Parete finita Finished Wall
- Si = Sede interna Internal Space

LUCE DI PASSAGGIO CLEAR OPENING SIZE		MISURA D'INGOMBRO STRUCTURAL OPENING SIZE		PARETE FINITA/SEDE INTERNA FINISHED WALL /INTERNAL SPACE
L	H	Li	Hi*	Pf / Si
600÷1000	1800÷2700	690÷1090 Intonaco plaster	1870÷2870	<b>105 Intonaco/plaster</b> <b>100 Cartongesso/ plasterboard</b>

\* Ingombro massimo con un angolo di 60° \* Maximum volume at an angle of 60°

Le particolari caratteristiche del telaio rendono indispensabile l'abbinamento con la ferramenta specifica.

The frame needs to be combined with its specific hardware fittings.

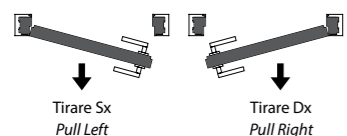

# LACCATE LACQUERED - TRAPEZOIDALE

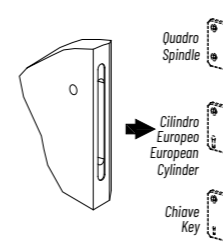
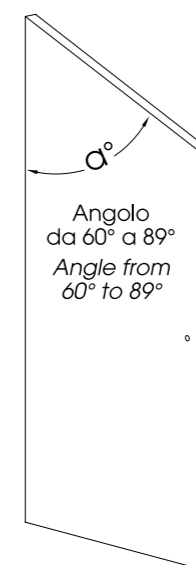

Anta predisposta per serratura magnetica  
Pre-mortised door (hole) for magnetic lock

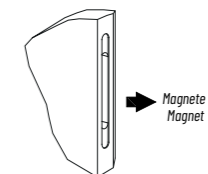

Anta predisposta per magnete  
Pre-mortised door (hole) for magnet

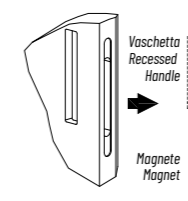

Anta predisposta per magnete  
e foro per vaschetta  
Pre-mortised door (hole)  
for magnet and recessed handle

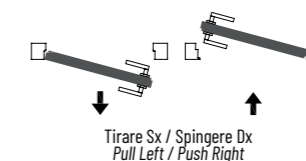

**LUCE DI PASSAGGIO CLEAR OPENING SIZE**

L	H
600 ÷ 1000	1800 ÷ 2700

\* Disponibile solo per ante laccate opache o con solo fondo

Prima di ordinare la porta è necessario verificare che la misura del telaio ordinato corrisponda all'effettiva misura della luce rilevata in cantiere dopo la posa.

\* Available only for mat panel or panel with primer.

Before ordering the panels, it is necessary to check that the measure of the frame corresponds to the effective clear opening size after onsite installation.