

# ACUSTICA

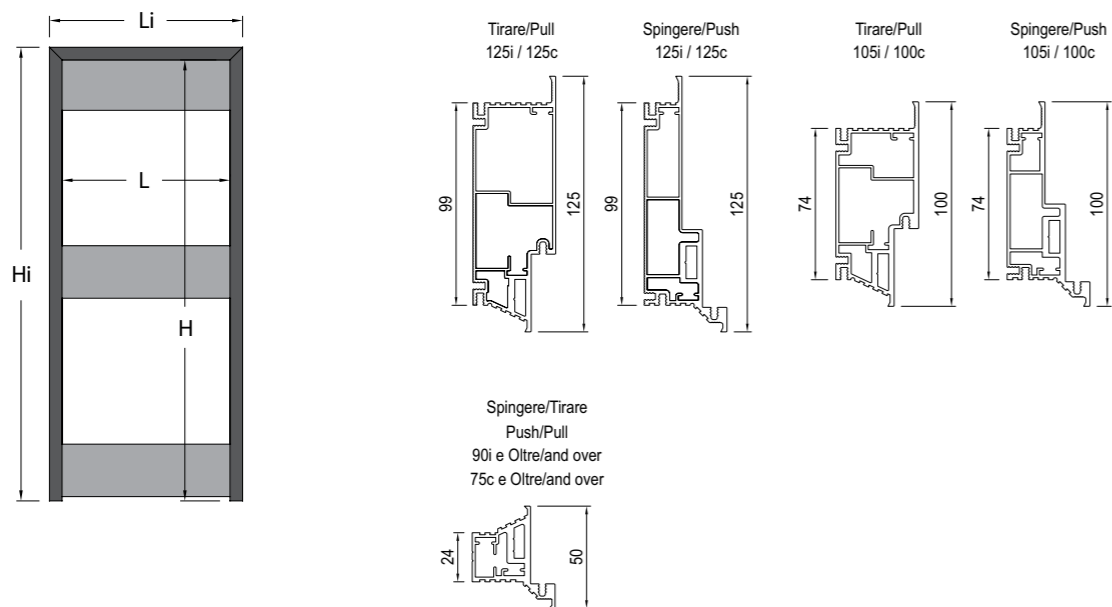

Per parete Intonaco e cartongesso 100/125 mm - modello a Tirare.  
Pull model, for masonry and for plasterboard 100/125 mm.

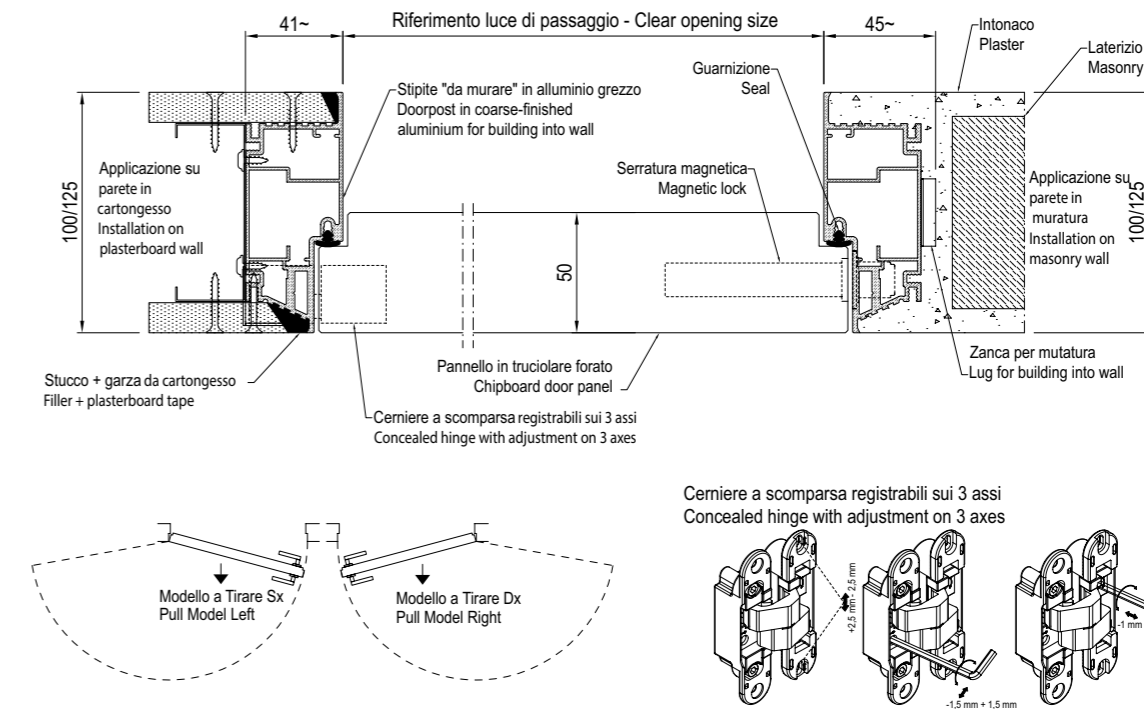

**Legenda Legend**

- L = Larghezza luce Opening Width
- H = Altezza luce Opening Height
- Li = Ingombro in larghezza Overall Width
- Hi = Ingombro in altezza Overall Height
- Pf = Parete finita Finished Wall
- Si = Sede interna Internal Space

LUCE DI PASSAGGIO CLEAR OPENING SIZE		MISURA D'INGOMBRO STRUCTURAL OPENING SIZE		PARETE FINITA/SEDE INTERNA FINISHED WALL /INTERNAL SPACE
L	H	Li	Hi	Pf / Si
da 600 a 900	1800÷2400	da 692 a 992	1841÷2441	<b>105 Intonaco/100 Cartongesso</b> 105 plaster/100 plasterboard <b>125 Intonaco/125 Cartongesso</b> 125 plaster/125 plasterboard

Intonaco 105 mm e cartongesso 100 mm - modello a Spingere.  
Push model, for masonry thickness 105 mm and for plasterboard 100 mm.

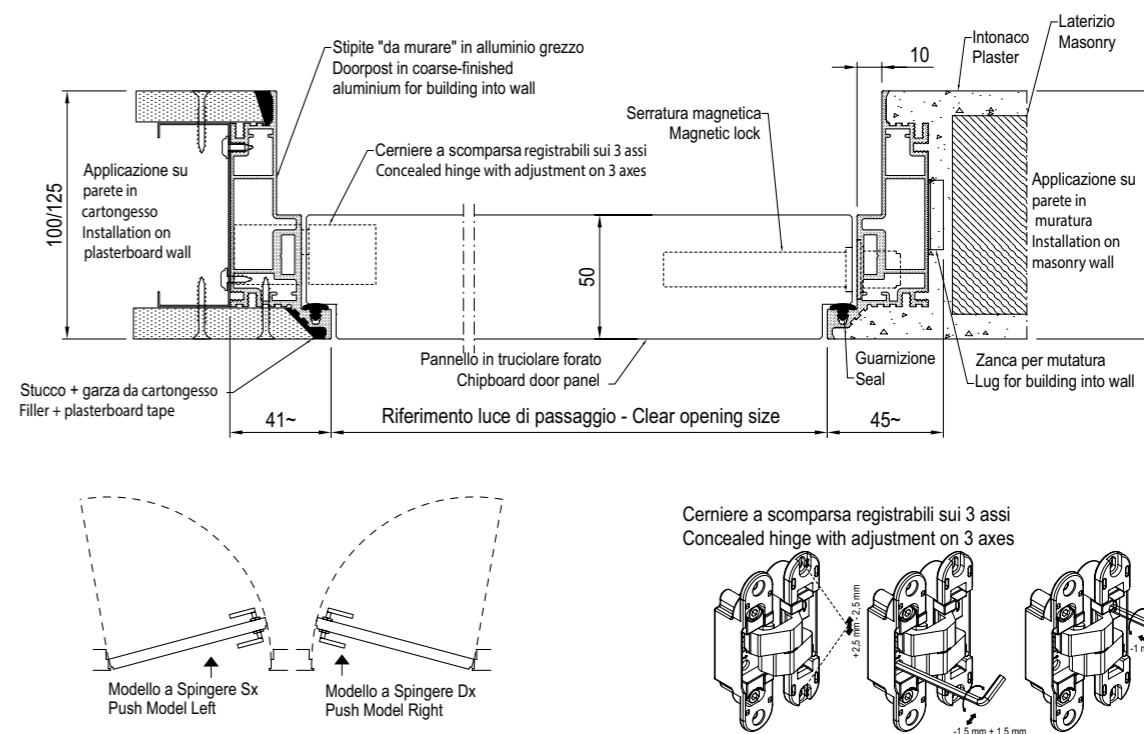

**Intonaco 105 - Cartongesso 100 • plaster 105 - Plasterboard 100**

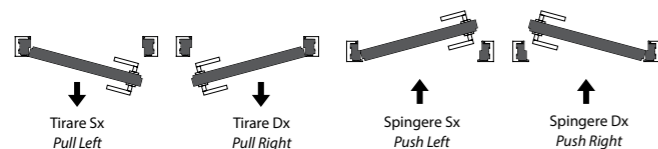

La versione a spingere consente l'apertura massima dell'anta di 90°/100°, con conseguente riduzione della luce di passaggio.  
In caso di affiancamento di porte a Spingere e Tirare sulla stessa parete, fra i due modelli, a parità di luce di passaggio, il foro luce del modello Tirare presenta una differenza in altezza di + 10 mm e in larghezza di + 20 mm. Le particolari caratteristiche del telaio rendono indispensabile l'abbinamento con la ferramenta specifica.

The push version permits maximum door opening to 90°/100°, with a consequent reduction of the clear opening width. If push and pull models are placed adjacently on the same wall, the clear opening size on the pull model is 10 mm higher and 20 mm wider than the push model. The special characteristics of the frame make it essential for it to be combined with its specific hardware fittings.

**Intonaco 125- Cartongesso 125 • plaster 125 - Plasterboard 125**

