

PORTA BATTENTE REVERSIBILE
 PORTE BATTANTE RÉVERSIBLE
 PUERTA BATIENTE REVERSIBLE
 REVERSIBLE SWING DOOR
 REVERSIBLE DREHFLÜGELTÜR

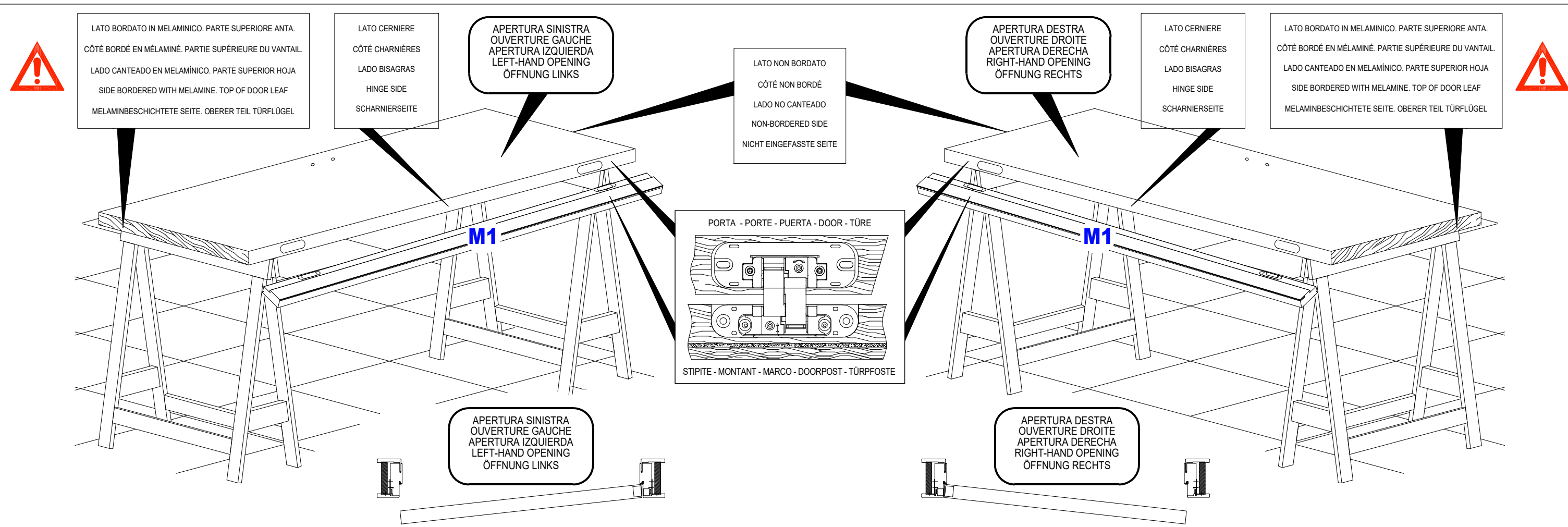

The information given in this document is for descriptive purposes only. SCRIGNO S.p.A. will not be held responsible for any inaccuracies caused by printing errors, transcription errors or for any other reason, and reserves the right to make modifications, without giving prior notice, for the improvement of its products. The reproduction, including the partial reproduction, of this document is severely prohibited within the terms of the Law.

Bei den veröffentlichten Daten handelt es sich um Richtwerte. Die Scrigno S.p.A. lehnt jegliche Haftung für auf Druckfehler oder andere Ursachen zurückzuführende Ungenauigkeiten ab, und behält sich das Recht vor, jederzeit ohne Vorankündigung Verbesserungen am Produkt vorzunehmen. Der Nachdruck ist auch auszugsweise gesetzlich untersagt.

Los datos publicados son indicativos. La sociedad SCRIGNO S.p.A. declina toda responsabilidad por los posibles errores contenidos, debido a errores de imprenta, de transcripción o cualquier otro motivo y se reserva el derecho de mejorar los productos sin previo aviso. La reproducción total o parcial esta prohibida por la ley.

Ces informations sont remises à titre indicatif. SCRIGNO S.p.A. décline toute responsabilité en cas d'erreur d'impression, de traduction, ou pour tout autre motif. Elle se réserve le droit d'apporter toute modification pour le montage et l'amélioration du produit sans préavis. Toute reproduction même partielle de ce document est formellement interdite.

I dati pubblicati sono indicativi. SCRIGNO S.p.A. declina ogni responsabilità per le possibili inesattezze contenute, dovute ad errori di stampa, di trascrizione o per qualsiasi altro motivo e si riserva il diritto di apportare modifiche atte a migliorare i prodotti senza preavviso. La riproduzione anche parziale è severamente vietata a norme di legge.

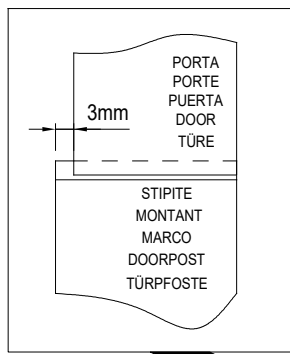

APERTURA SINISTRA
OUVERTURE GAUCHE
APERTURA IZQUIERDA
LEFT-HAND OPENING
ÖFFNUNG LINKS

ADATTARE IN LARGHEZZA
ADAPTER EN LARGEUR
ADAPTAR EN ANCHURA
ADJUST WIDTH
BREITE ANPASSEN

APERTURA DESTRA
OUVERTURE DROITE
APERTURA DERECHA
RIGHT-HAND OPENING
ÖFFNUNG RECHTS

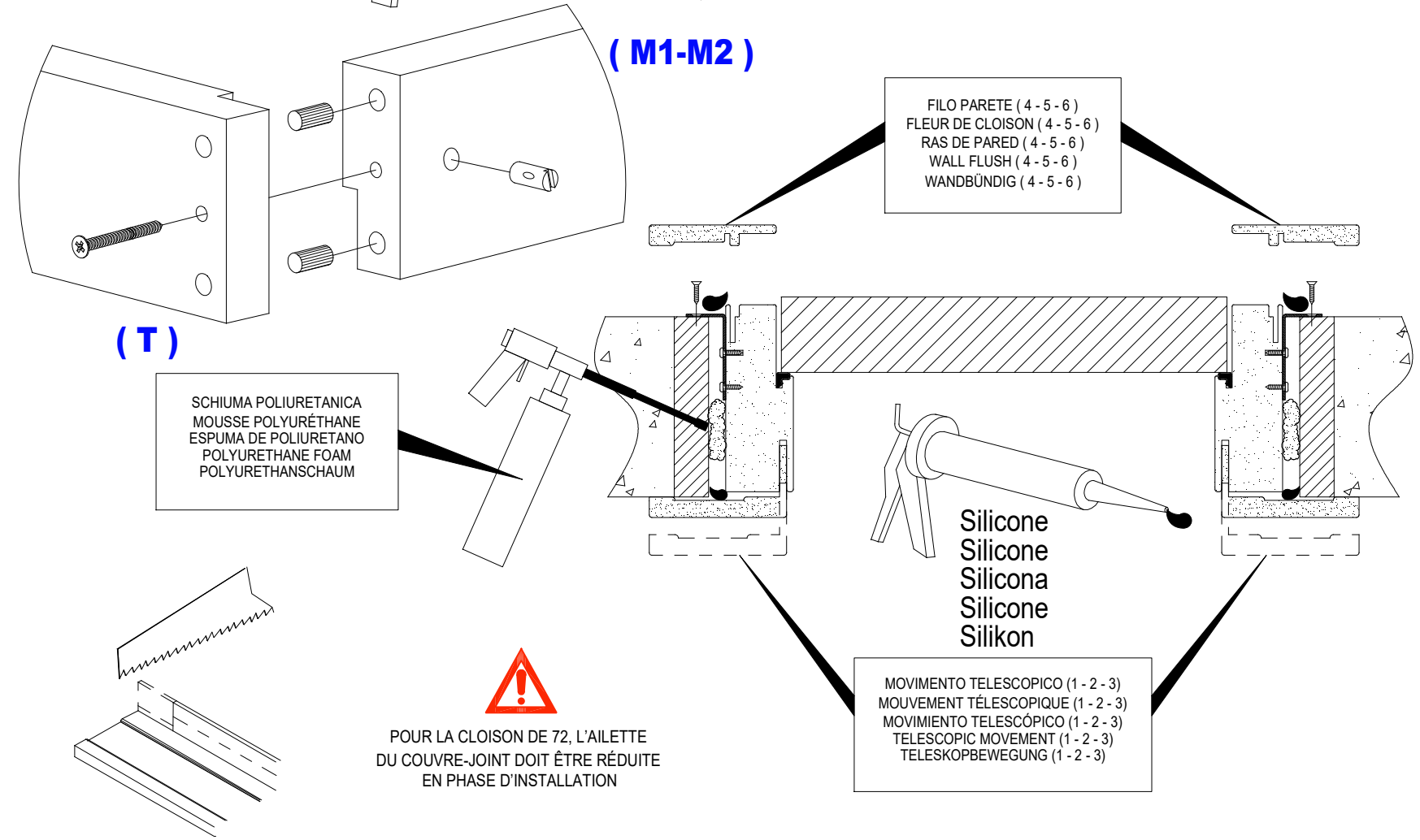
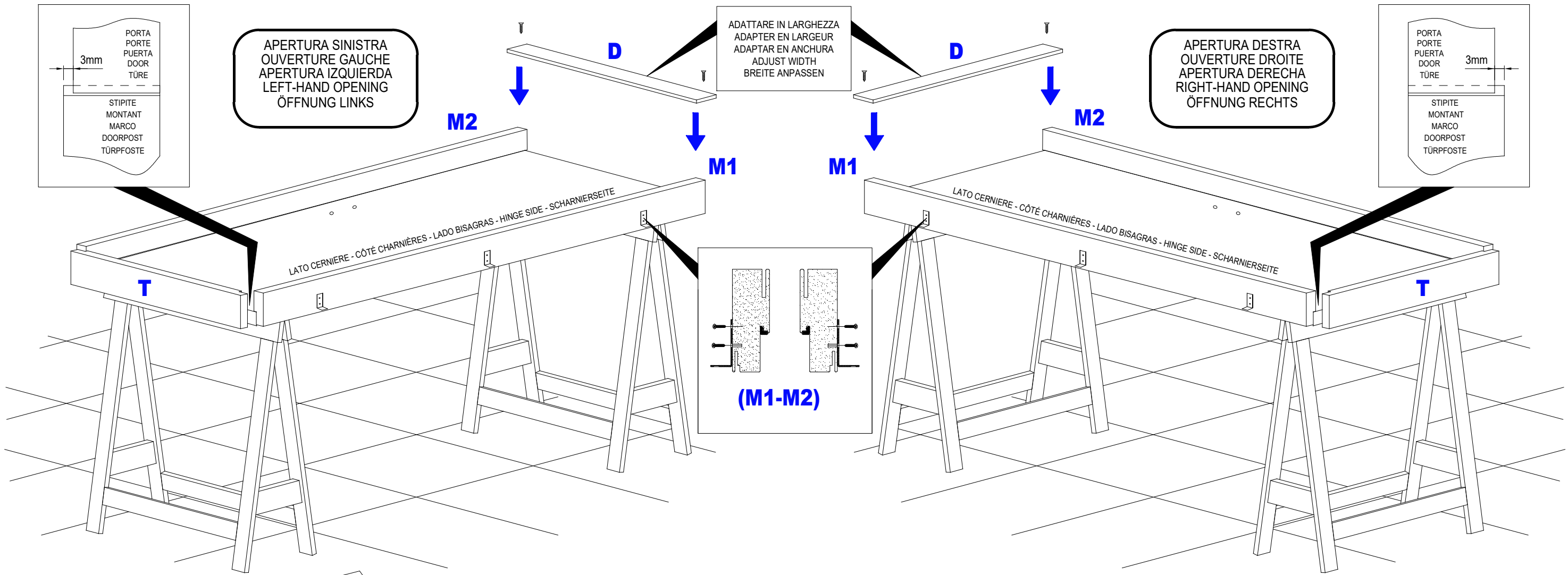
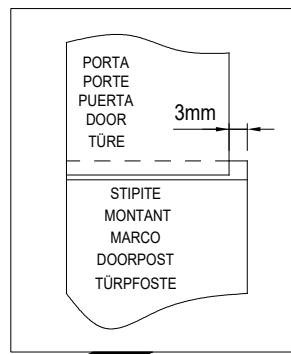

REGOLAZIONI
RÉGLAGES
AJUSTES
ADJUSTMENTS
REGELUNGEN

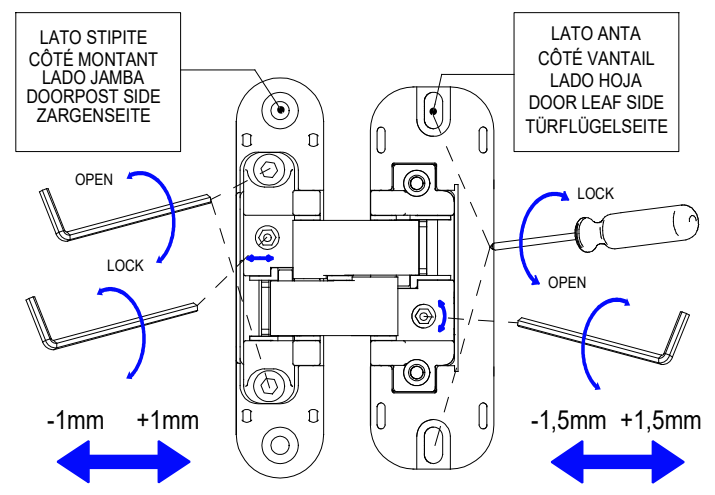
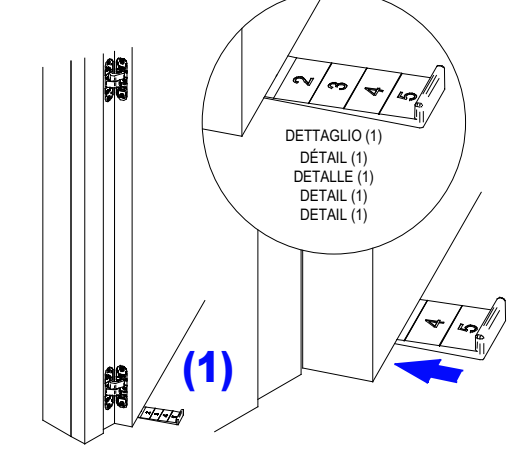

A LAVORO ULTIMATO APPLICARE I CARTER DI COPERTURA SULLE CERNIERE.
LE TRAVAIL TERMINÉ, APPLIQUER LES CARTERS DE PROTECTION SUR LES CHARNIÈRES
UNA VEZ TERMINADO EL TRABAJO, APLICAR LAS PROTECCIONES DE COBERTURA SOBRE LAS BISAGRAS.
WHEN FINISHED, APPLY THE COVERING PANELS ONTO THE HINGES
NACH ABSCHLUSS DER ARBEITEN DIE GEHÄUSE ZUR ABDECKUNG AUF DEN SCHARNIEREN ANBRINGEN

