

Articolo venduto separatamente
Article vendu à part
Article sold separately

ESSENTIAL
125 CARTONGESSO 1 LASTRA
150 CARTONGESSO 2 LASTRE

ESSENTIAL
125 PLAQUES DE PLÂTRE 1 DALLE
150 PLAQUES DE PLÂTRE 2 DALLES

ESSENTIAL
125 PLASTERBOARD 1 PANEL
150 PLASTERBOARD 2 PANELS

ANTA ACUSTICA VANTAIL ACOUSTIQUE ACOUSTIC DOOR

Articolo venduto separatamente
Article vendu à part
Article sold separately

LUCE COMMERCIALE	LUCE EFFETTIVA	ANTA
DIMENSION DE PASSAGE COMMERCIAL	DIMENSION DE PASSAGE RÉEL	VANTAIL
OPENING SIZE COMMERCIAL	OPENING SIZE EFFECTIVE	DOOR
L	L - 10	Lp = L + 15
600	590	615
700	690	715
800	790	815
900	890	915
1000	990	1015

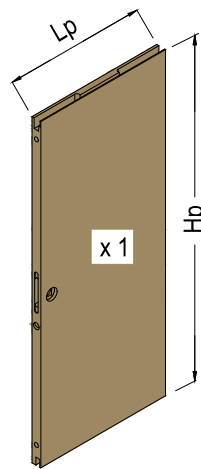

* VERIFICARE PRIMA DI ORDINARE LA PORTA
* VÉRIFIER AVANT DE COMMANDER LA PORTE
* CHECK BEFORE ORDERING THE DOOR

LUCE DIMENSION DE PASSAGE OPENING SIZE	ANTA VANTAIL DOOR
H	Hp = H - 6
2000*	1994
2045*	2039
2100*	2094

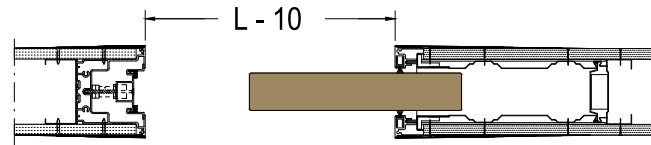
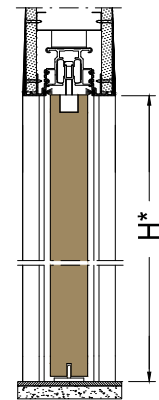

KIT FERRAMENTA - KIT QUINCAILLERIE - HARDWARE KIT

Articolo venduto separatamente
Article vendu à part
Article sold separately

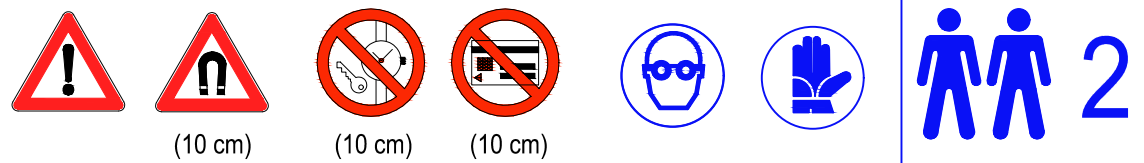
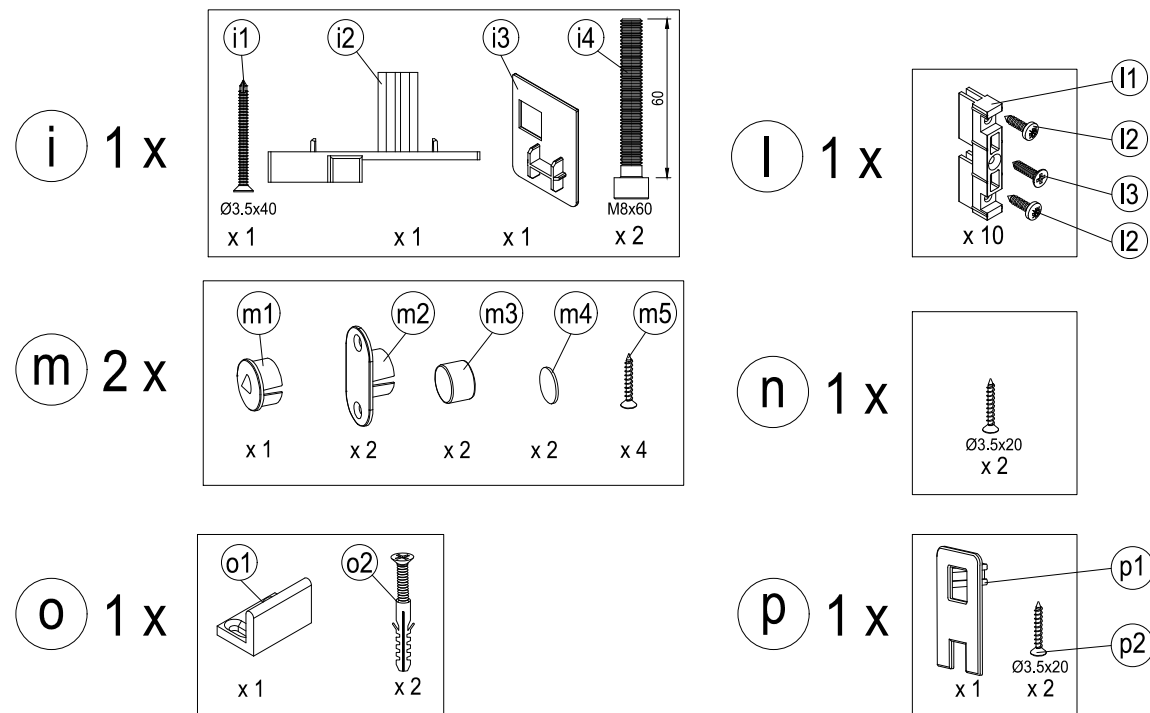
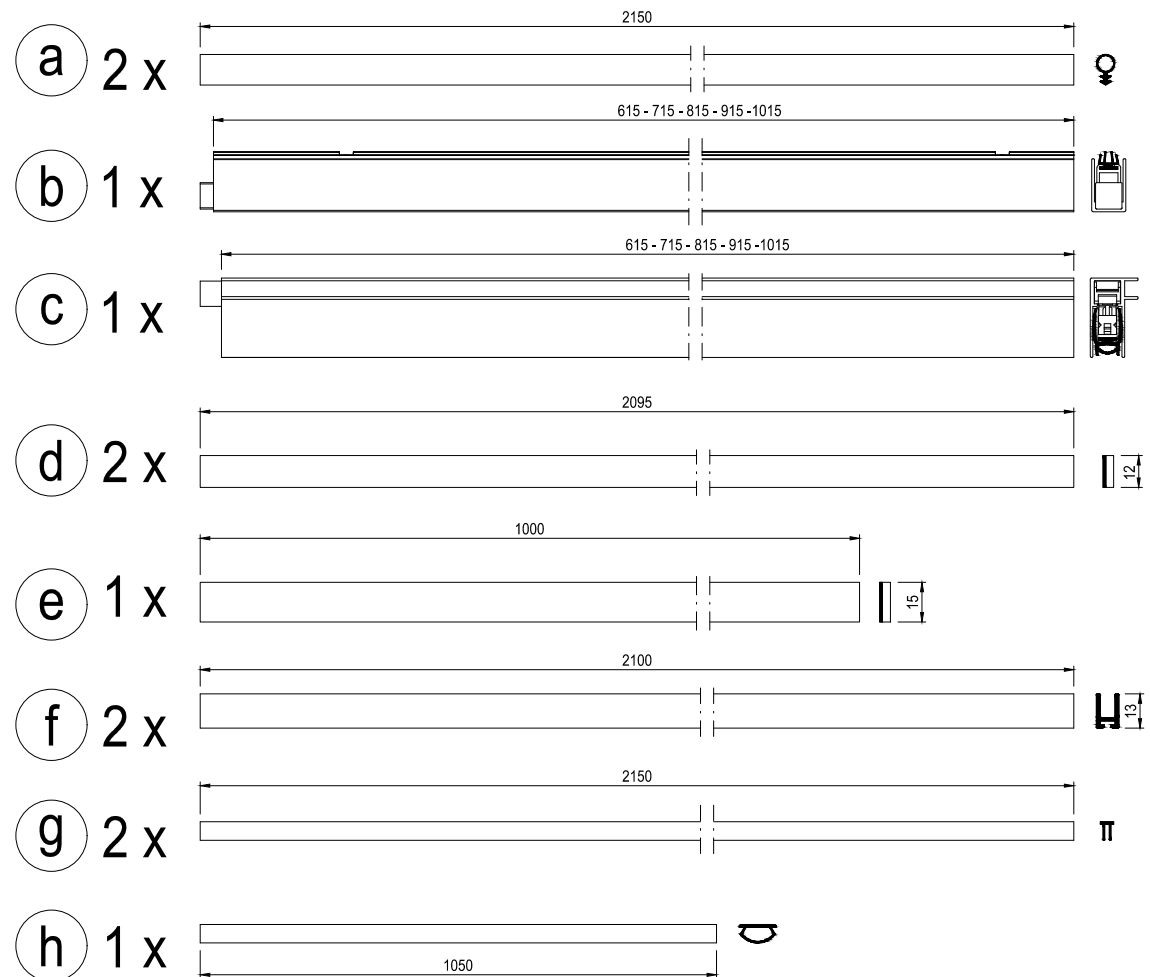

Nota: Test eseguito con telaio posato a regola d'arte, foro di passaggio 1000x2100 con kit chiudiscigno con serratura
Remarque : Essai exécuté avec le châssis posé dans les règles de l'art, dimension de passage 1000x2100 avec kit Chuidiscigno avec serrure
Note: Test done on a properly installed frame, 1000x2100 opening, Chuidiscigno kit with lock

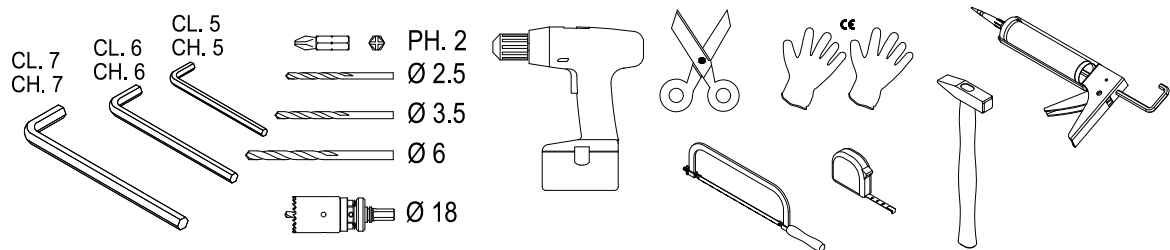

PREPARAZIONE ANTA - PRÉPARATION VANTAIL - DOOR PREPARATION

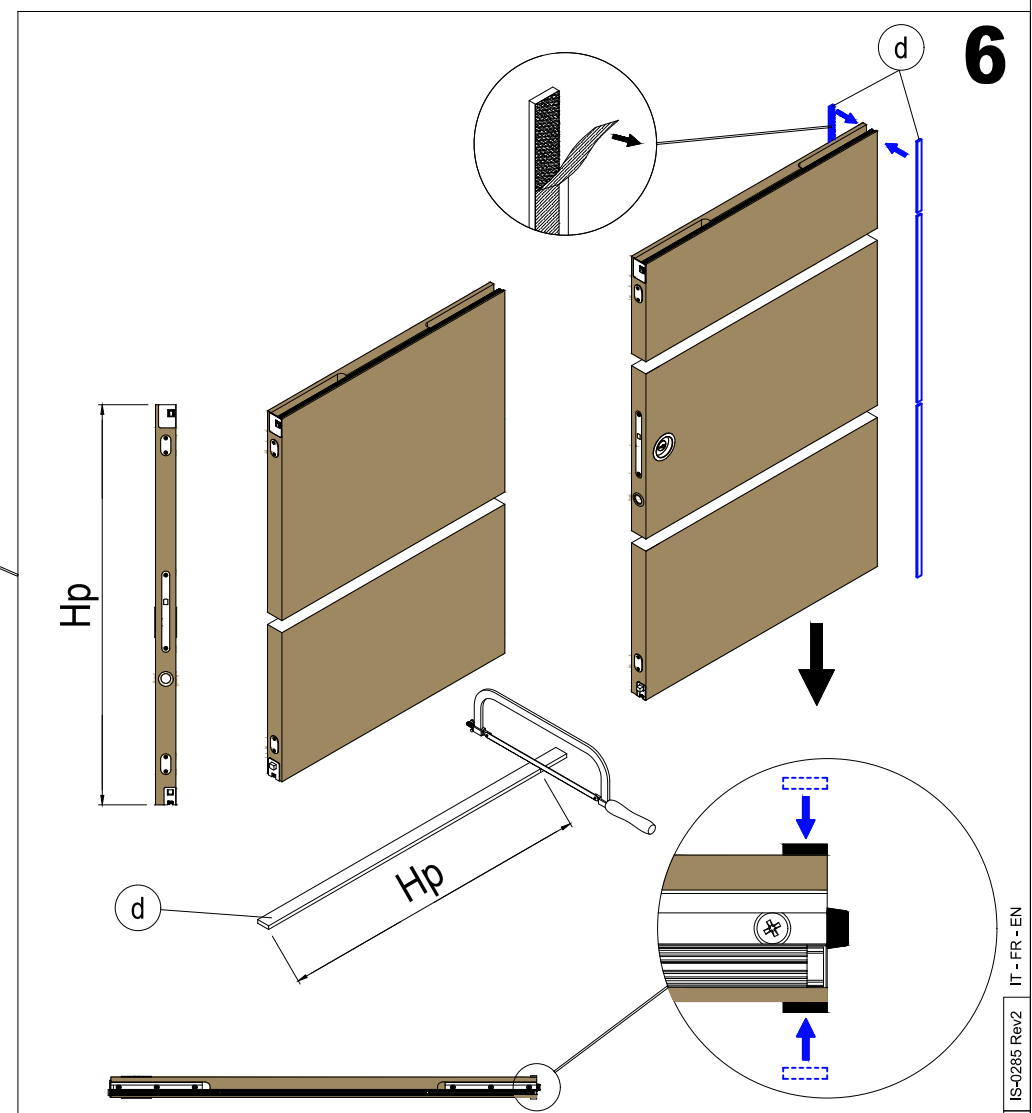
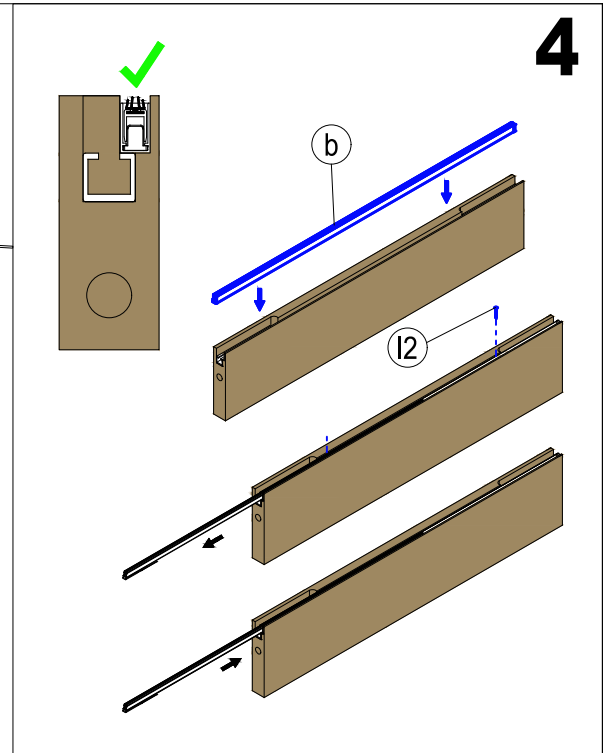
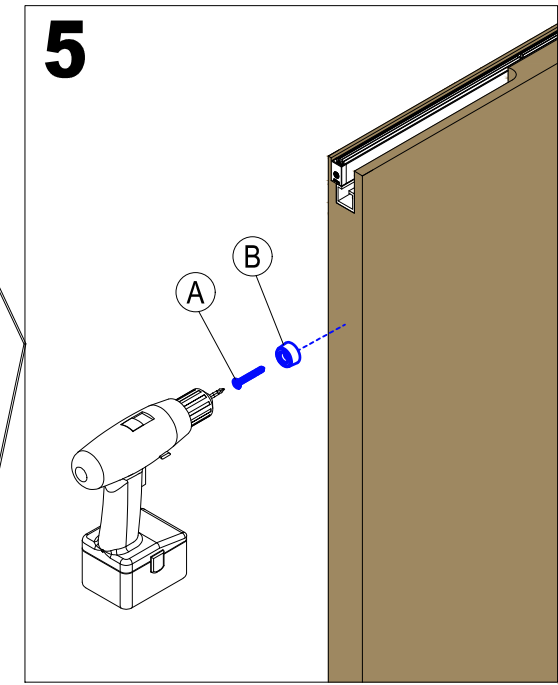
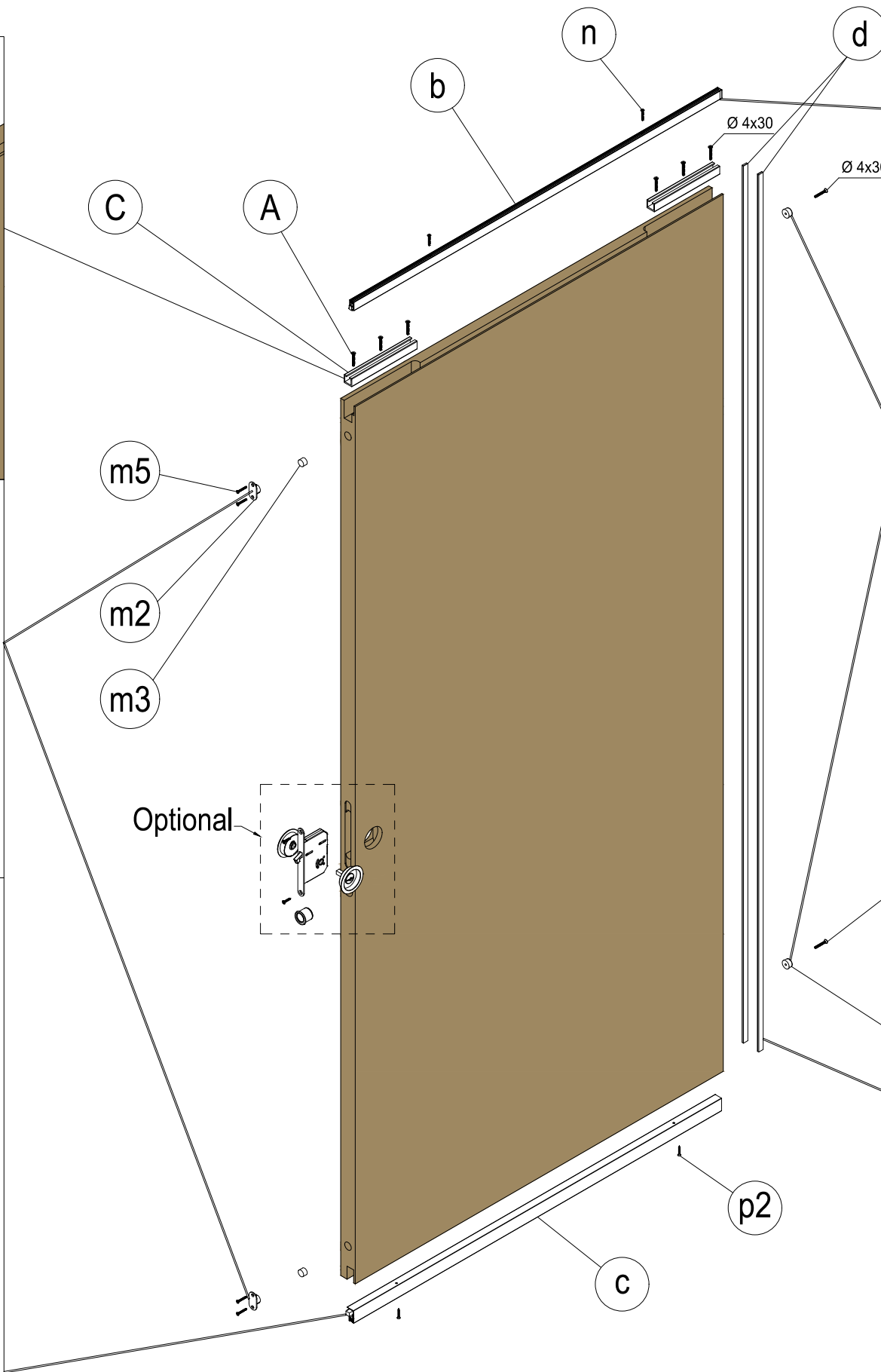
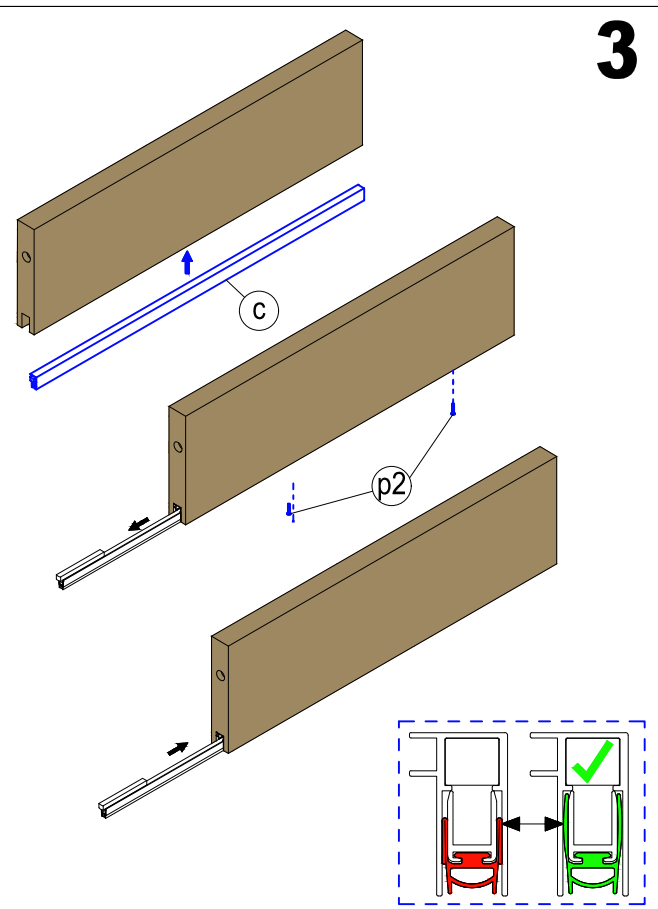
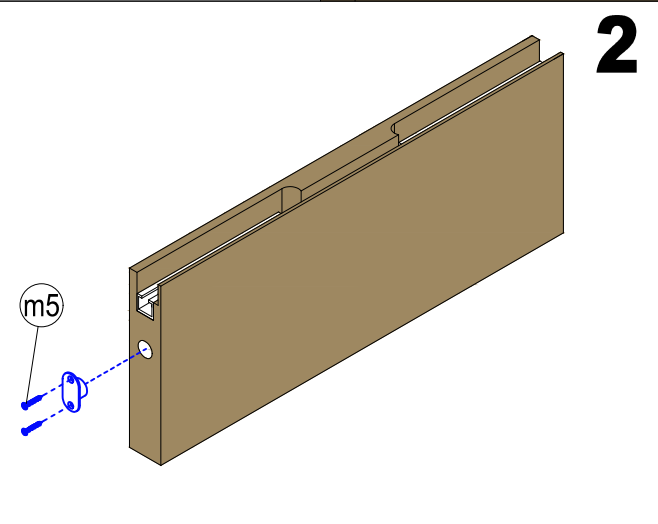
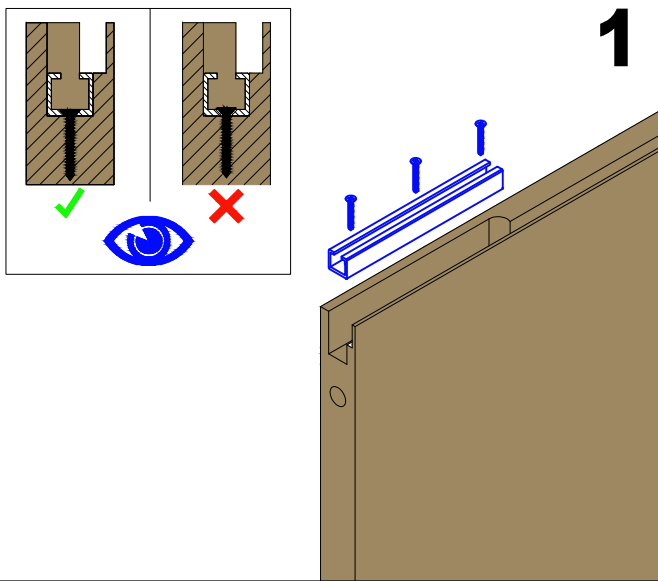

PRELEVARE I SEGUENTI ACCESSORI DALLA DOTAZIONE DEL CONTROTELAIO
 PRÉLEVER LES ACCESSOIRES SUIVANTS DE LA DOTATION DU CONTRE-CHÂSSIS
 PICK THE FOLLOWING ACCESSORIES FROM AMONG THOSE INCLUDED WITH THE FRAME

 Ø 4x30
 A x 8

 B x 2

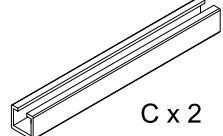
 C x 2

INSTALLAZIONE ANTA
 INSTALLATION VANTAIL
 DOOR INSTALLATION

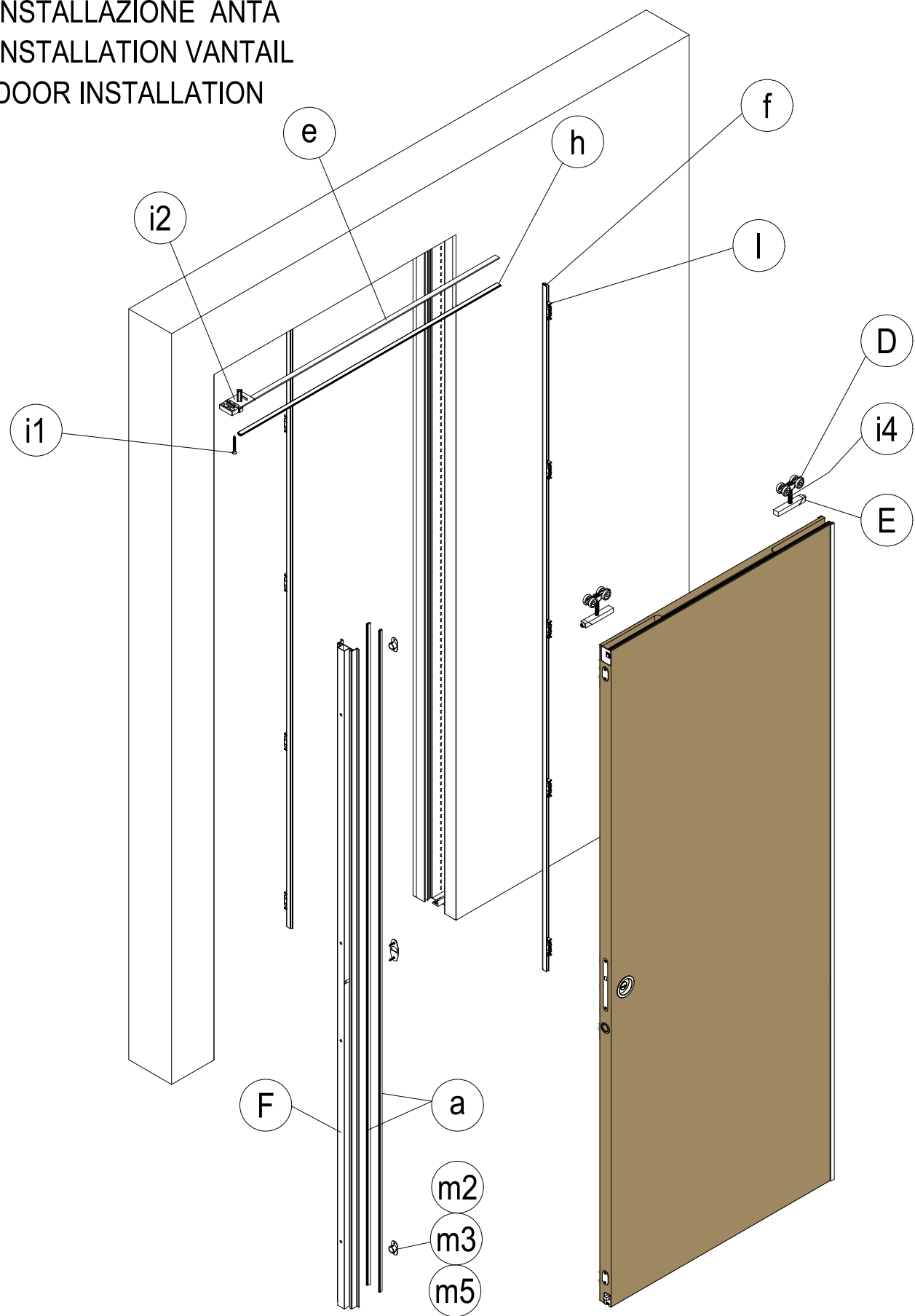

ACCESSORI DA PRELEVARE DALLA DOTAZIONE DEL CONTROTELAIO
 ACCESSOIRES À PRÉLEVER DE LA DOTAZION DU CONTRE-CHÂSSIS
 NECESSARY FRAME ACCESSORIES

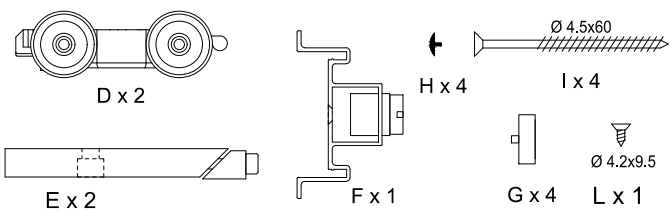

ACCESSORI NON NECESSARI
 ACCESSOIRES NON NÉCESSAIRES
 FRAME ACCESSORIES WHICH ARE NOT REQUIRED

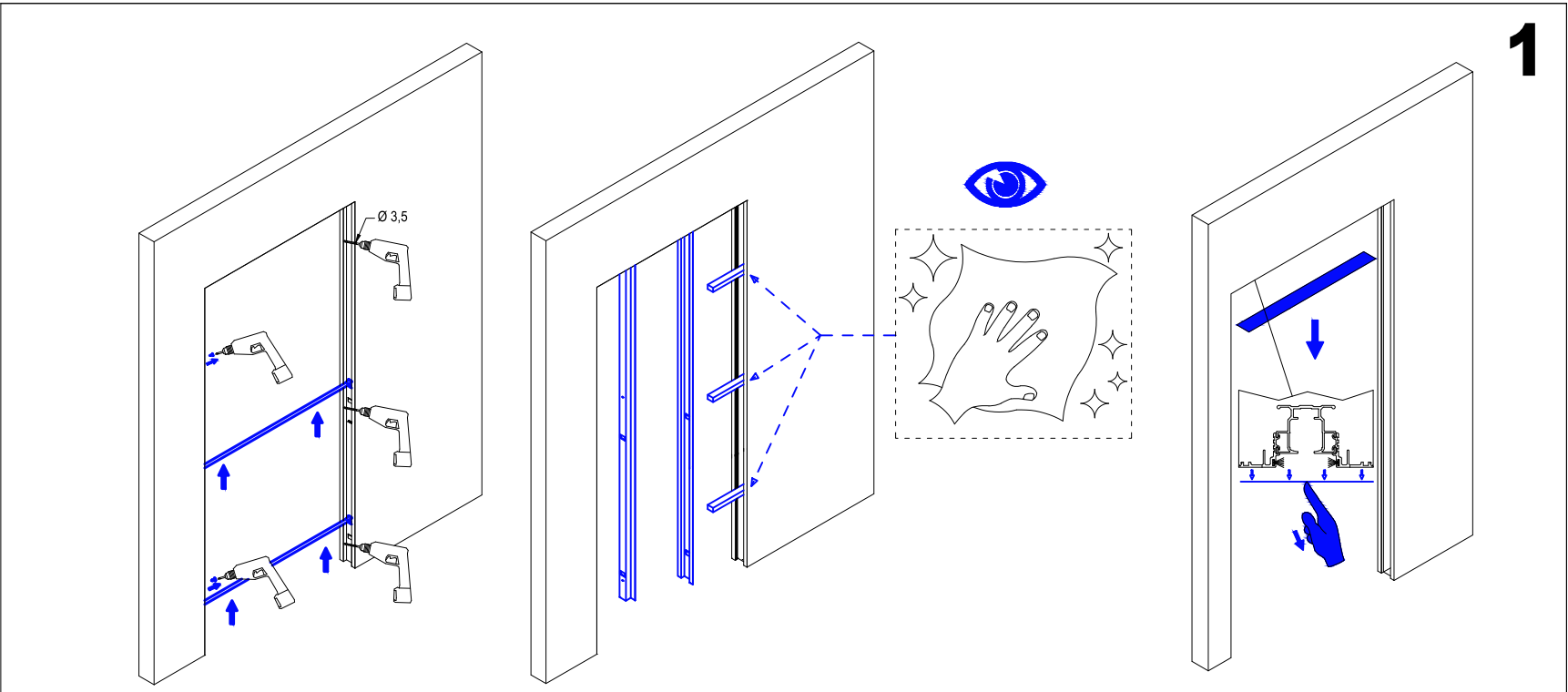
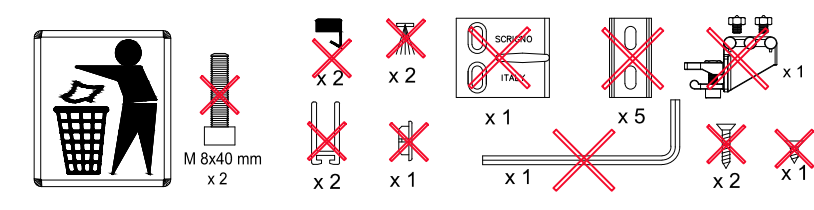

1

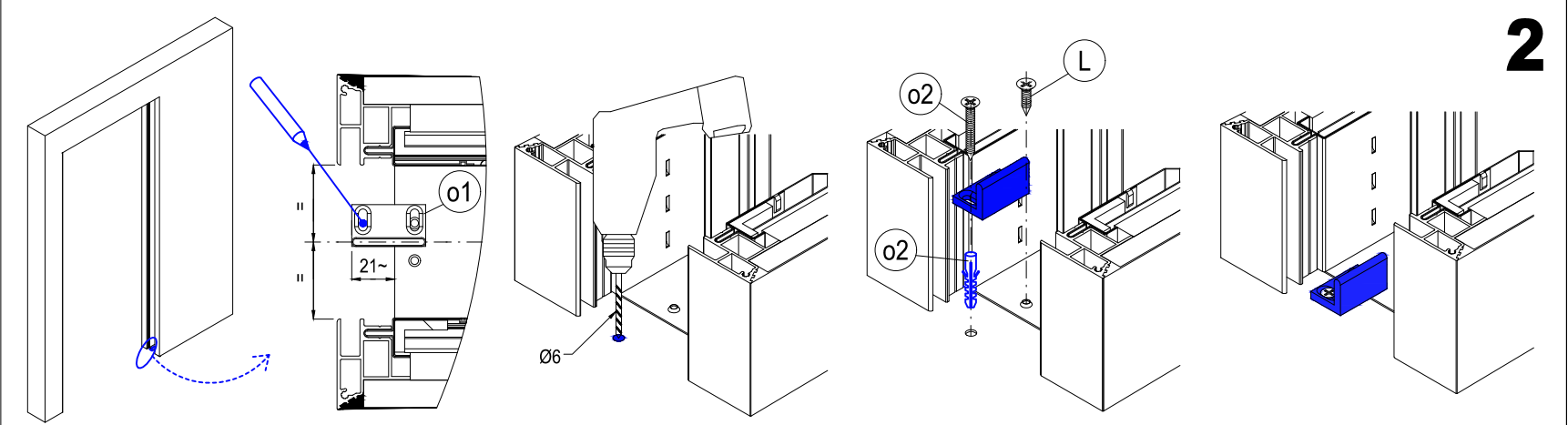

2

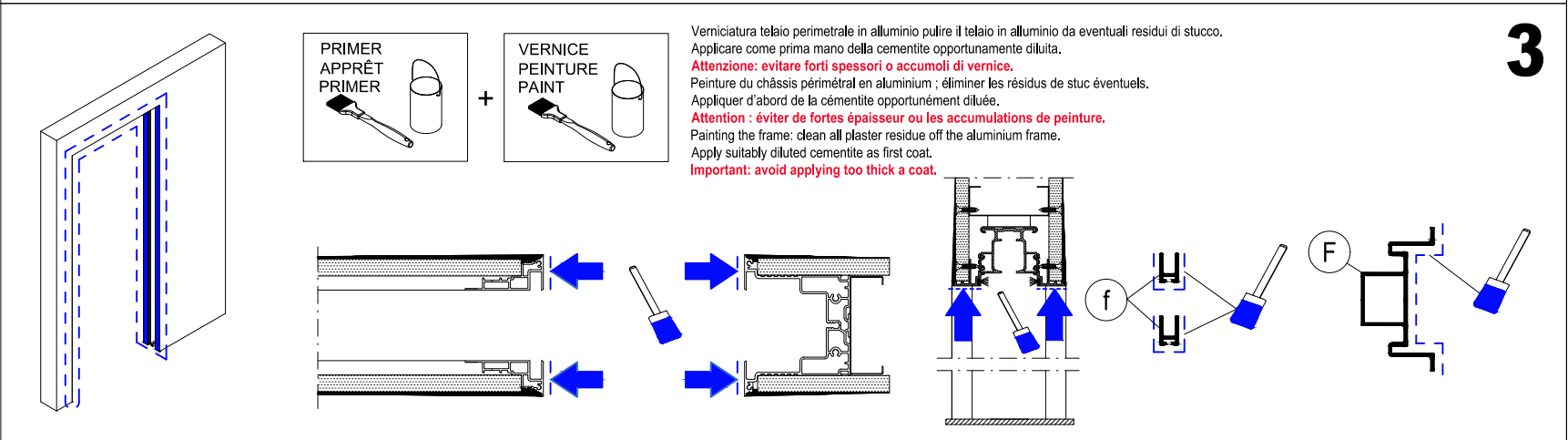

3

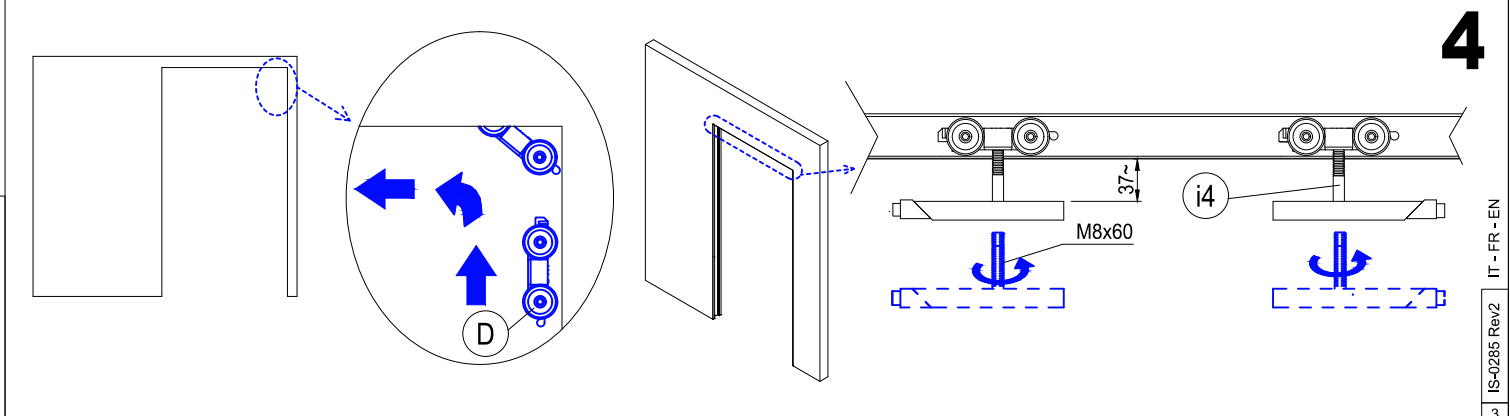

4

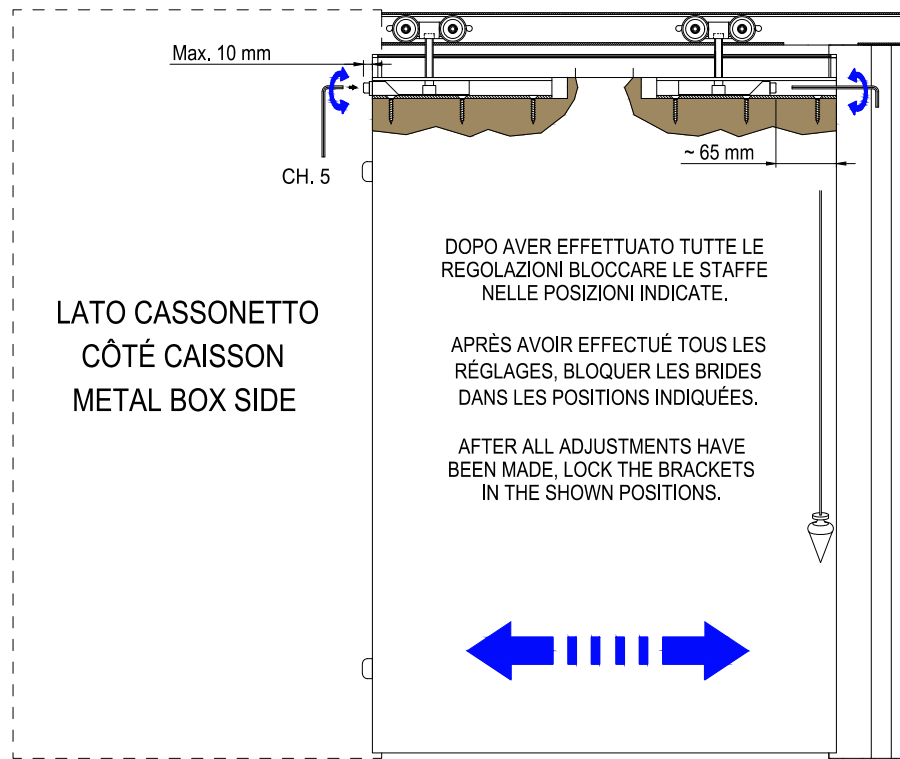
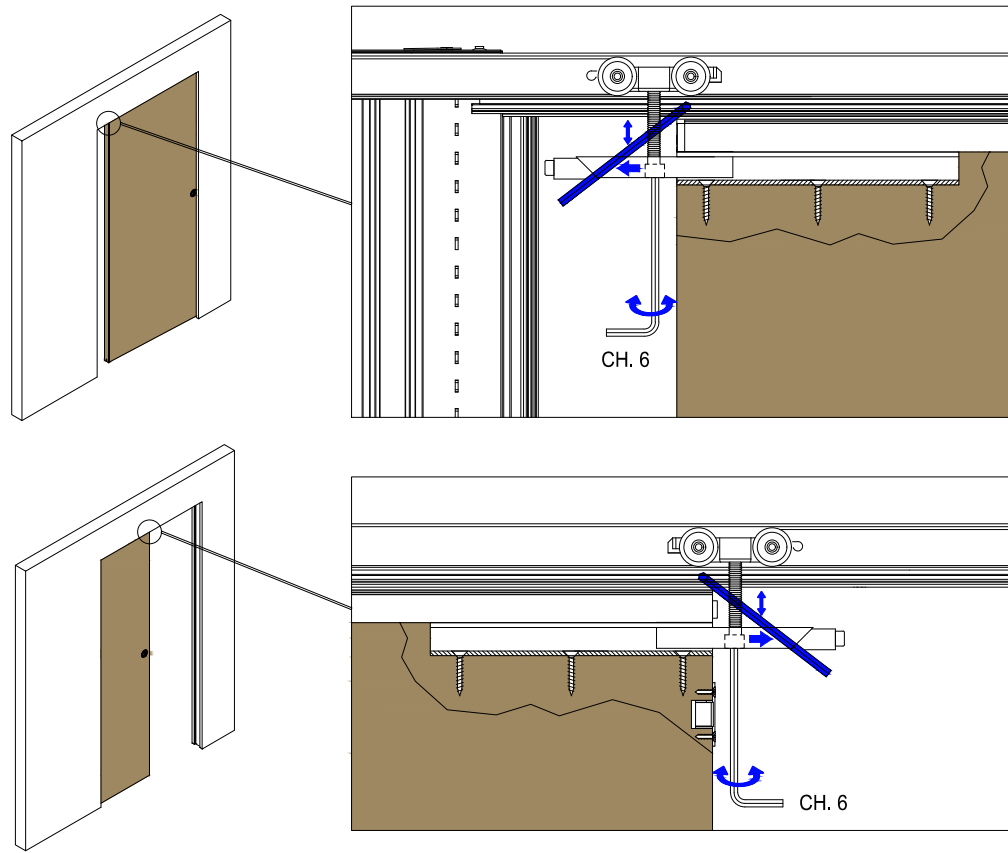

5

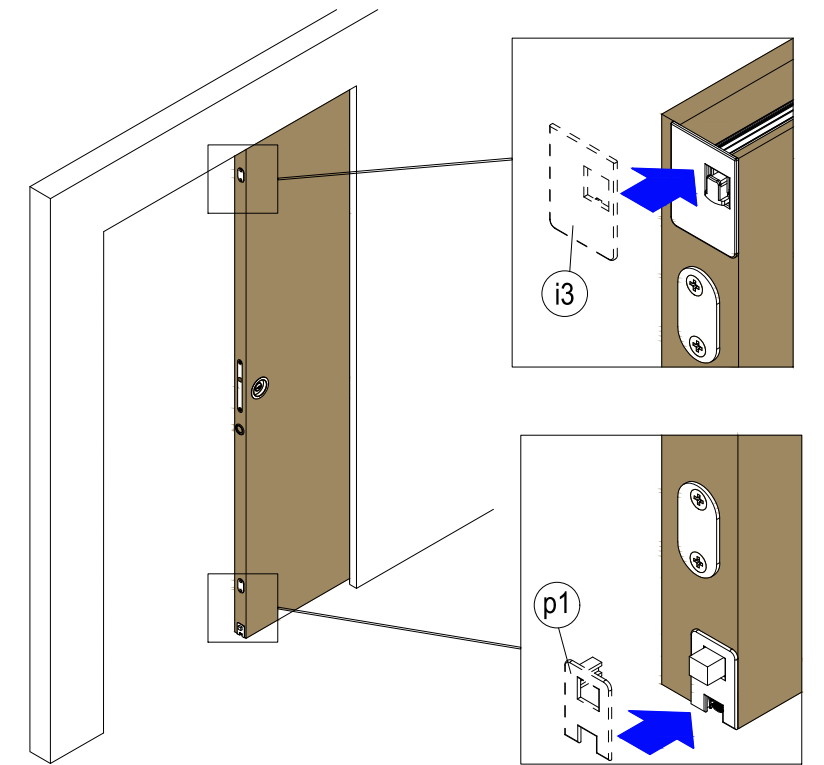

6

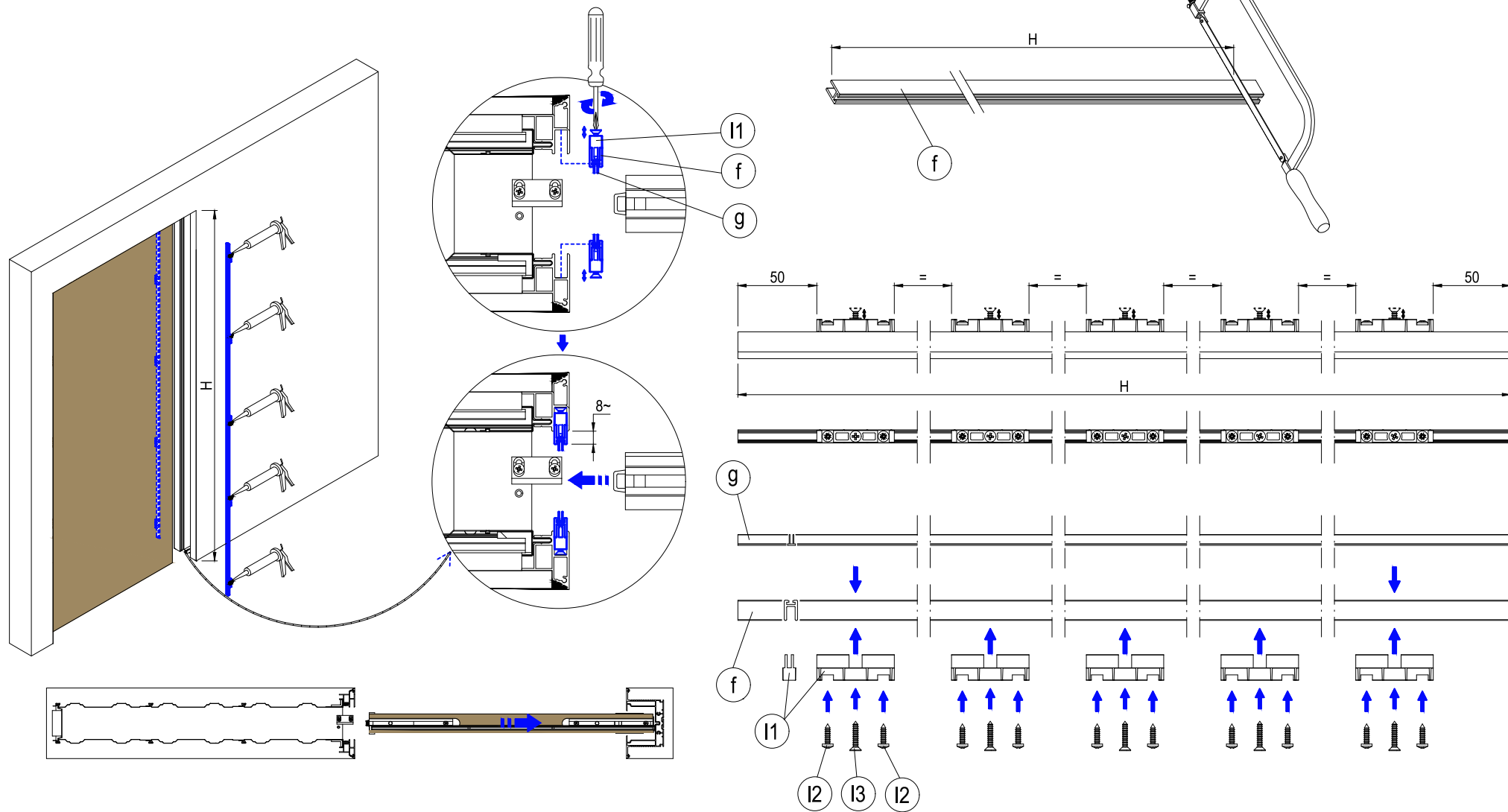

7

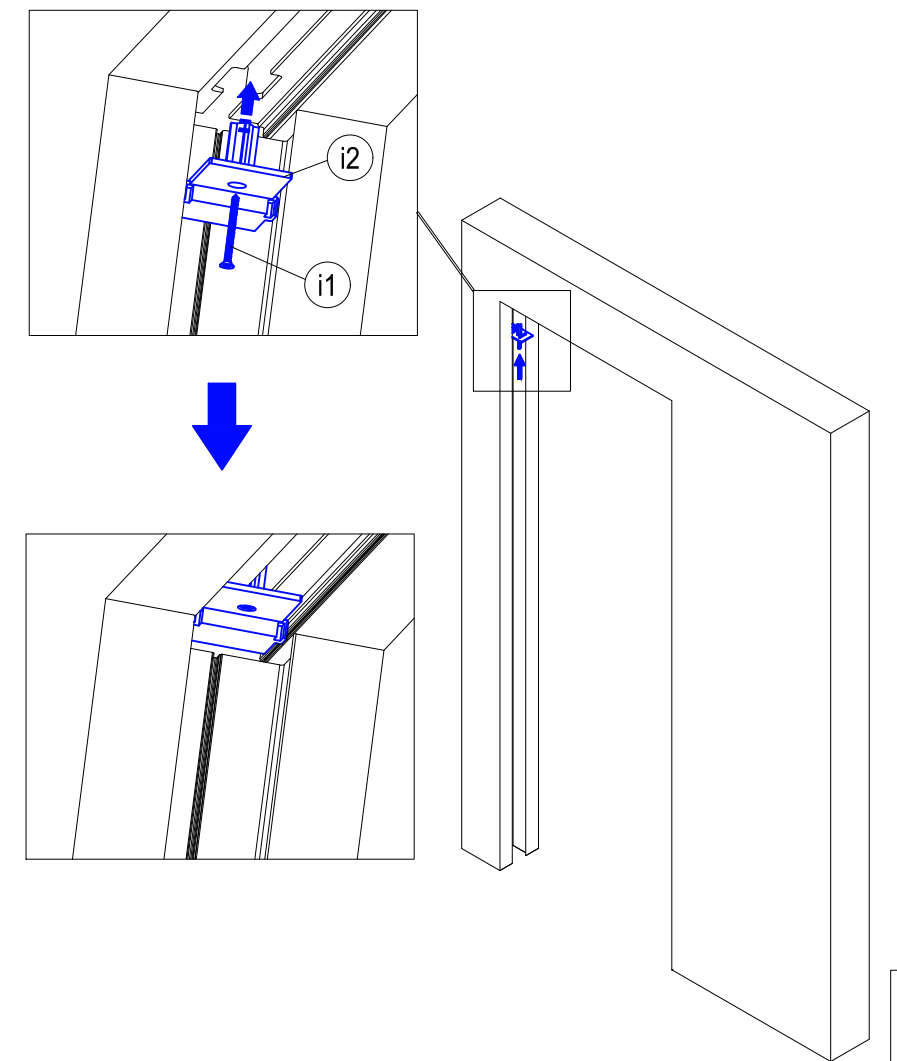

8

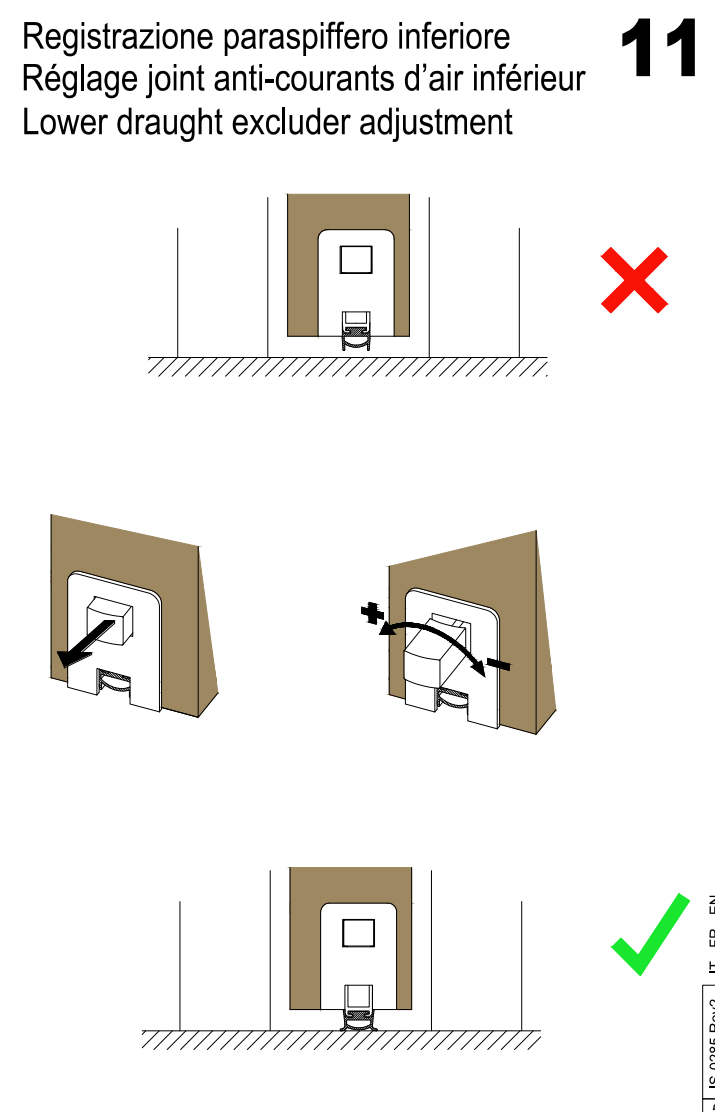
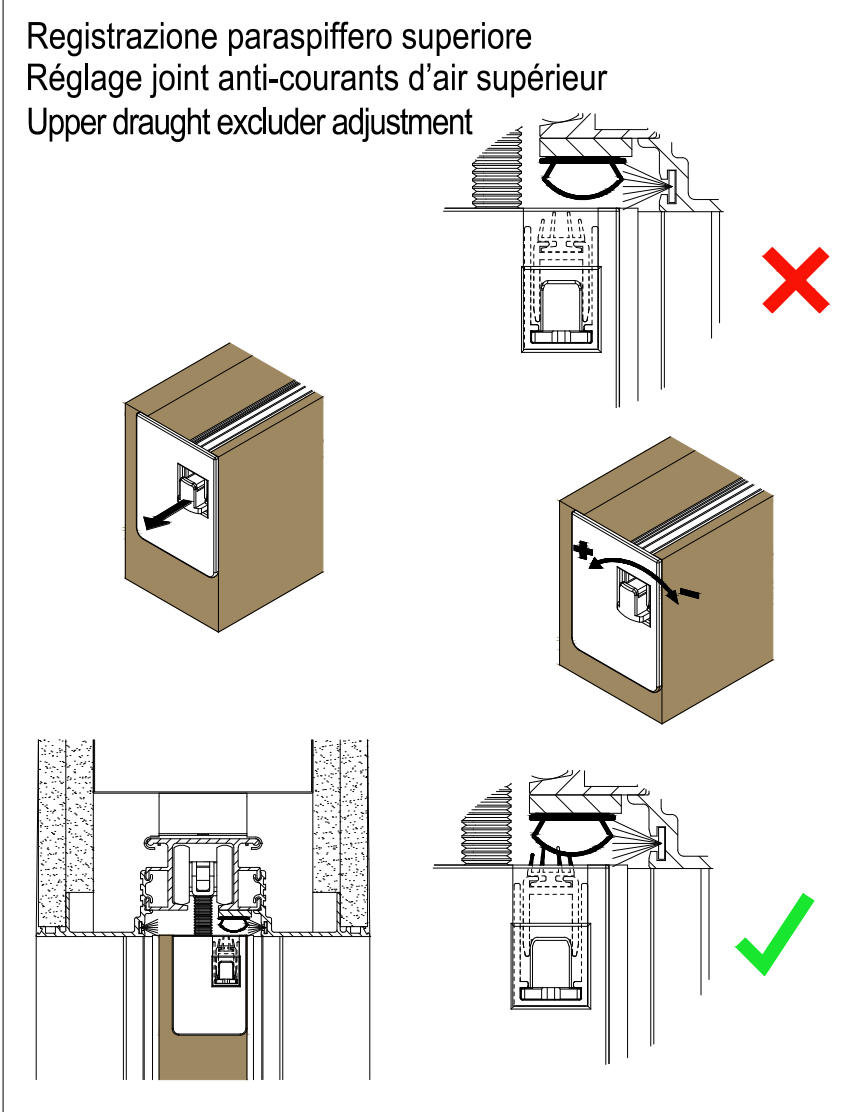
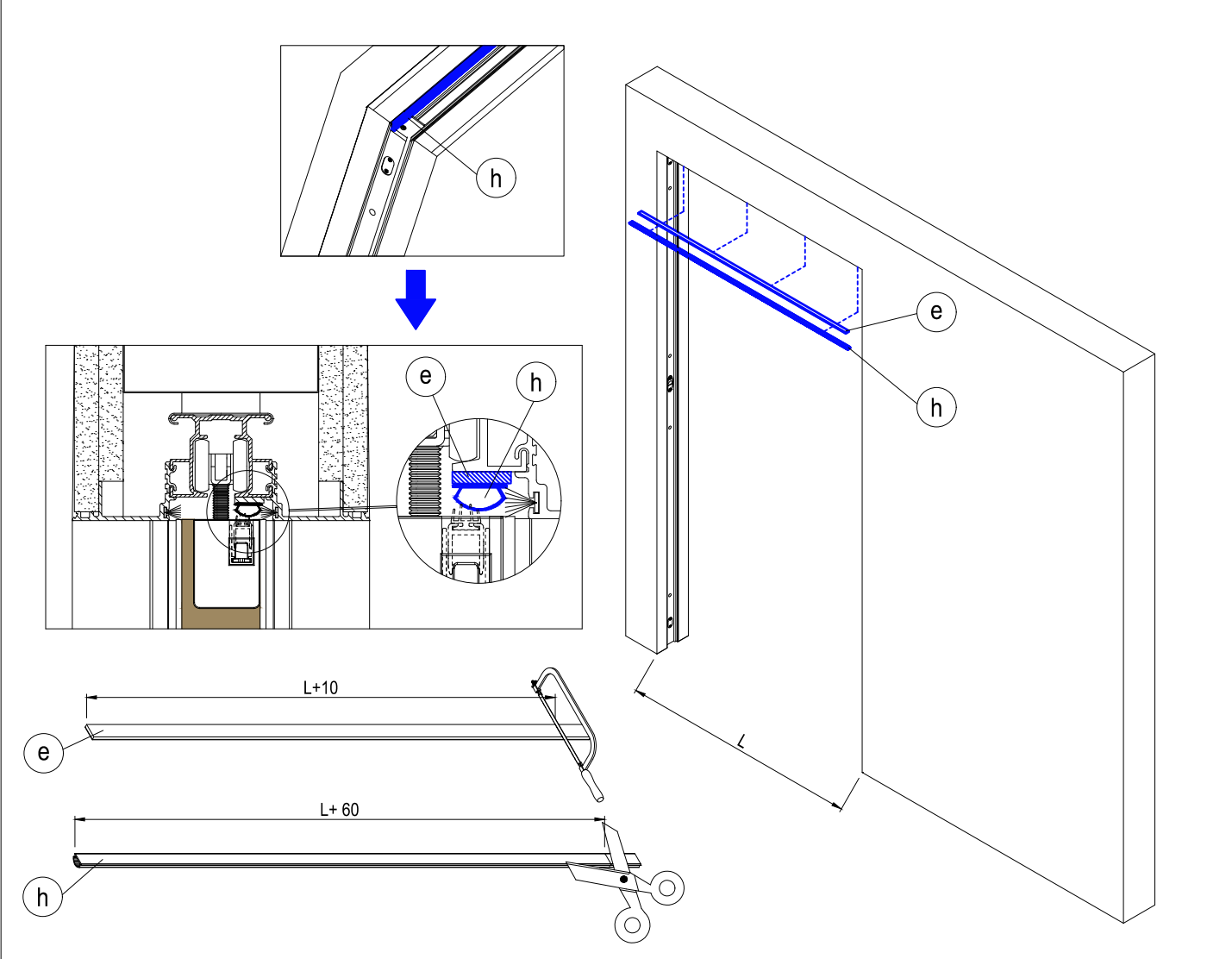
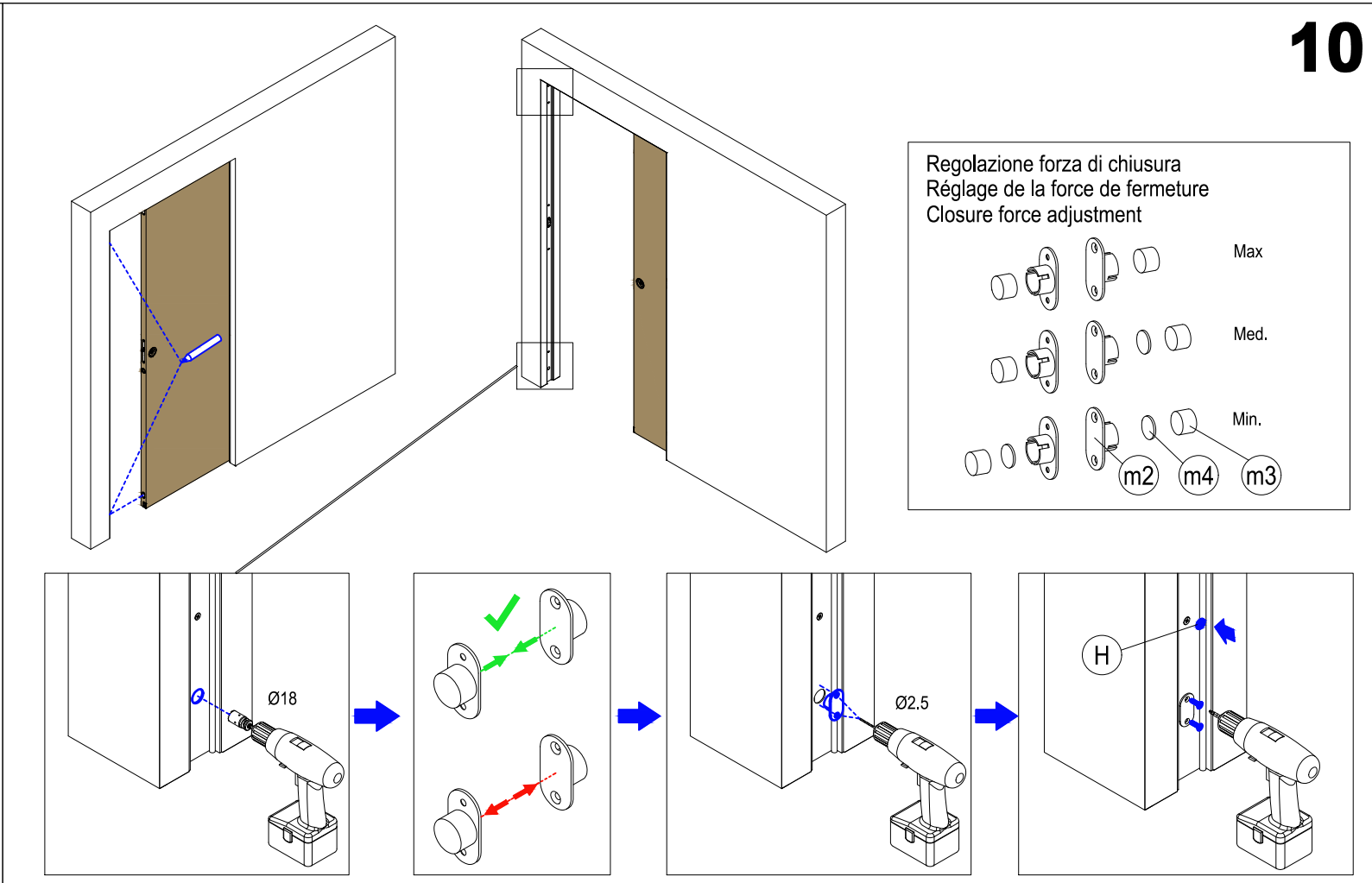
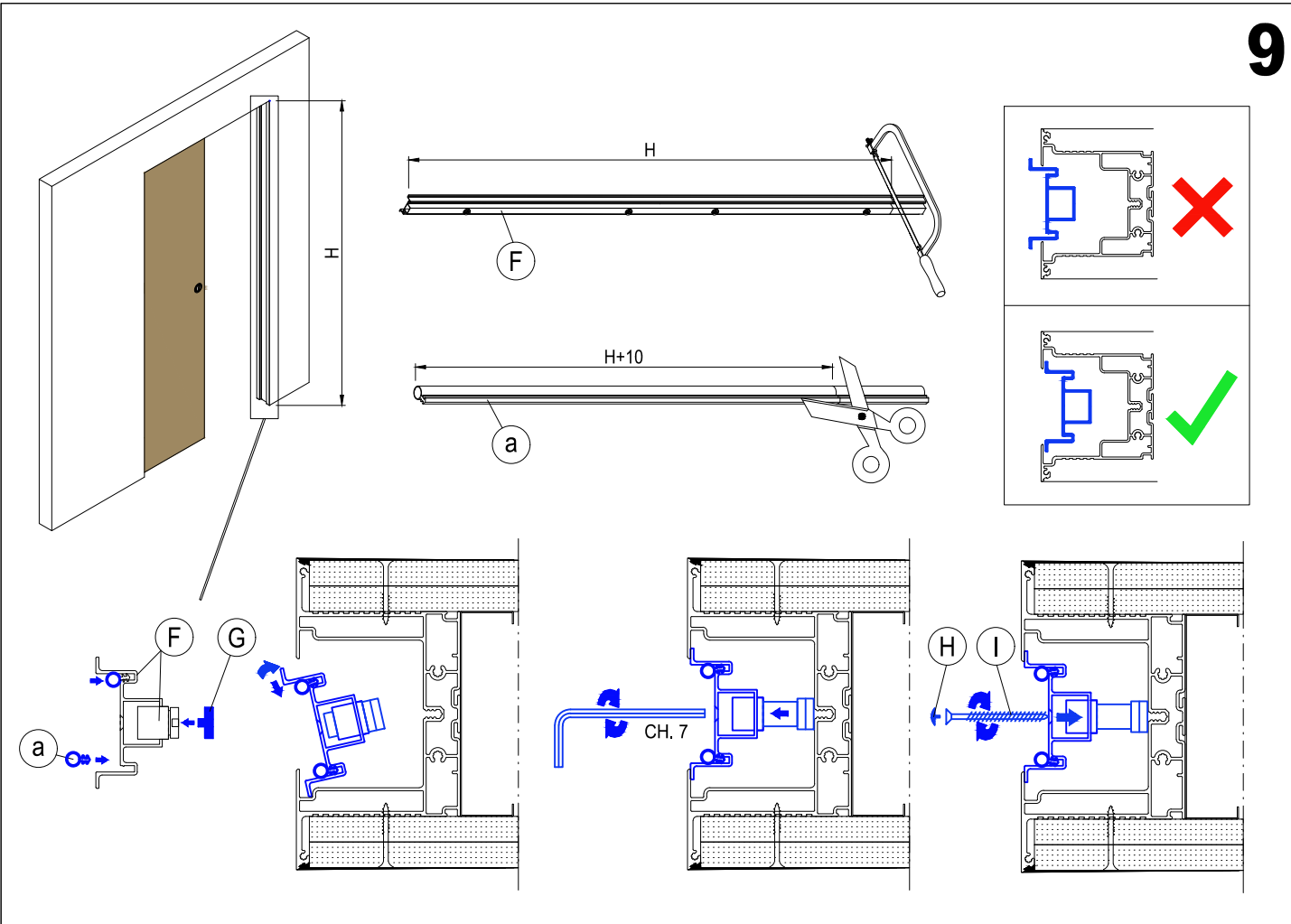

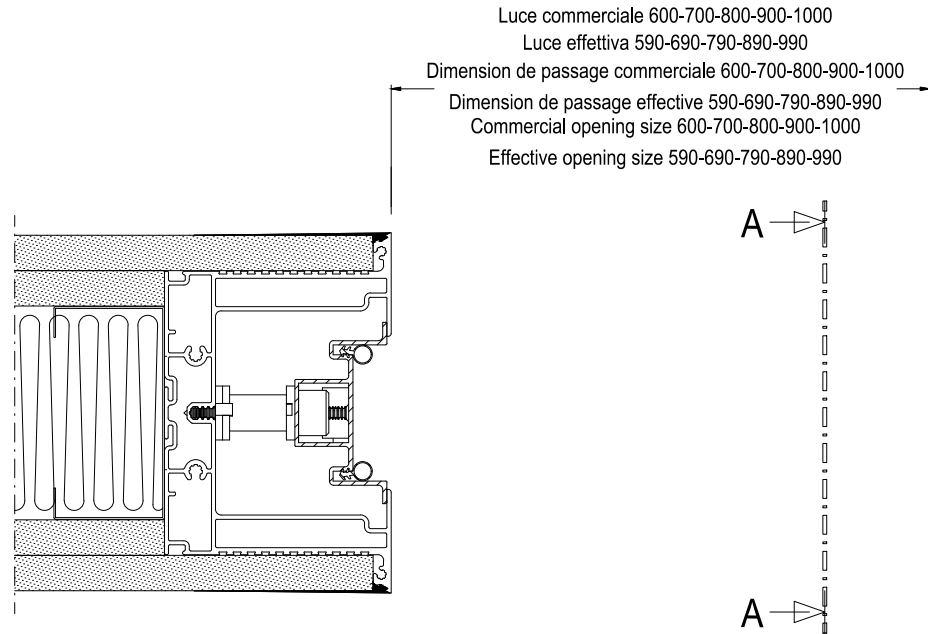

Sezione orizzontale 125 1L
porta aperta
Section horizontale 125 1 D
porte ouverte
Horizontal section one 125 Panel
open door

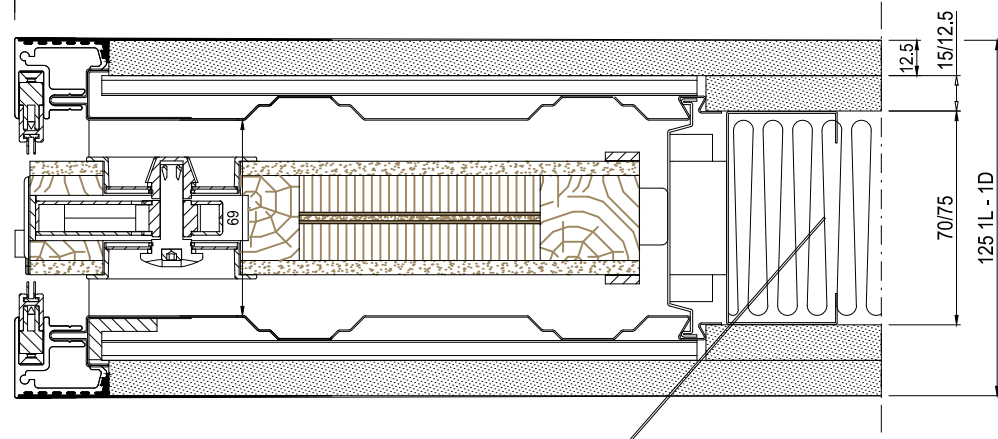

Costruzione flessibile standard. Parete in cartongesso a doppia lastra Sp.12,5 mm fissata a profili a U e C Sp.75 mm. Con Lana di vetro Sp. 70 densità 50 Kg/m³
Construction adaptable standard. Cloison en plaques de plâtre double dalle Ép. 12,5 et 15 mm fixée à des profils en U et C Ép. 70 mm. Avec laine de verre ép. 70 densité 50 kg/m³
Flexible standard construction. Plasterboard wall with double panel thickness 12.5 mm fixed to 75 mm thick U and C profiles. With 70 thickness fibreglass 50 kg/m³ density

Sezione A-A (125 1L)
Section A-A (125 1 D)
Section A-A (125 1L)

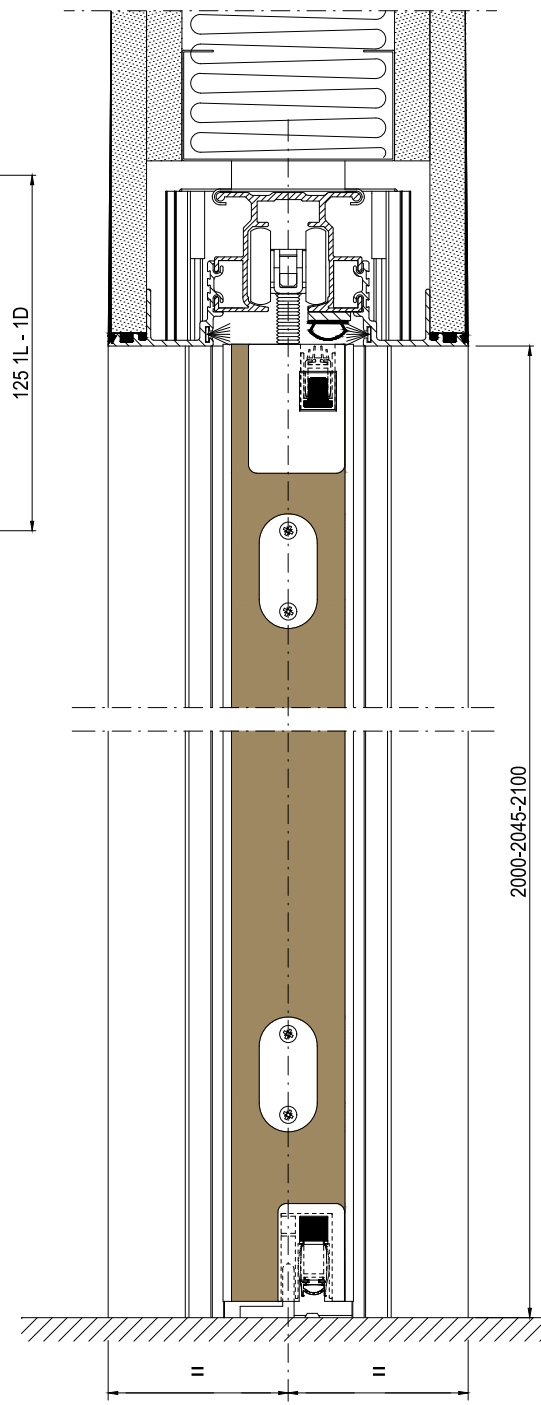

Sezione B-B (150 2L)
Section B-B (150 2 D)
Section B-B (150 2L)

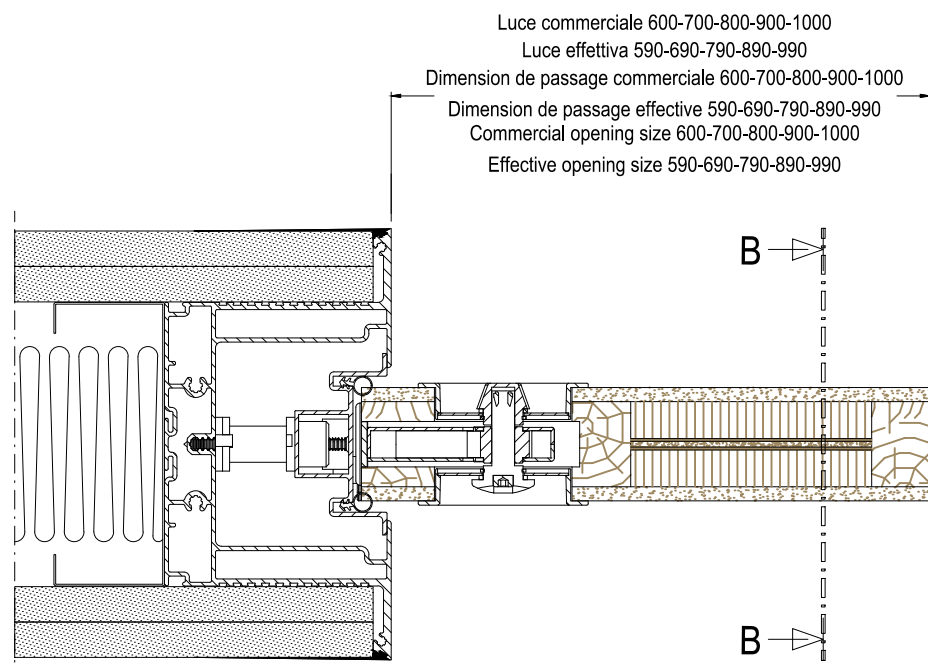
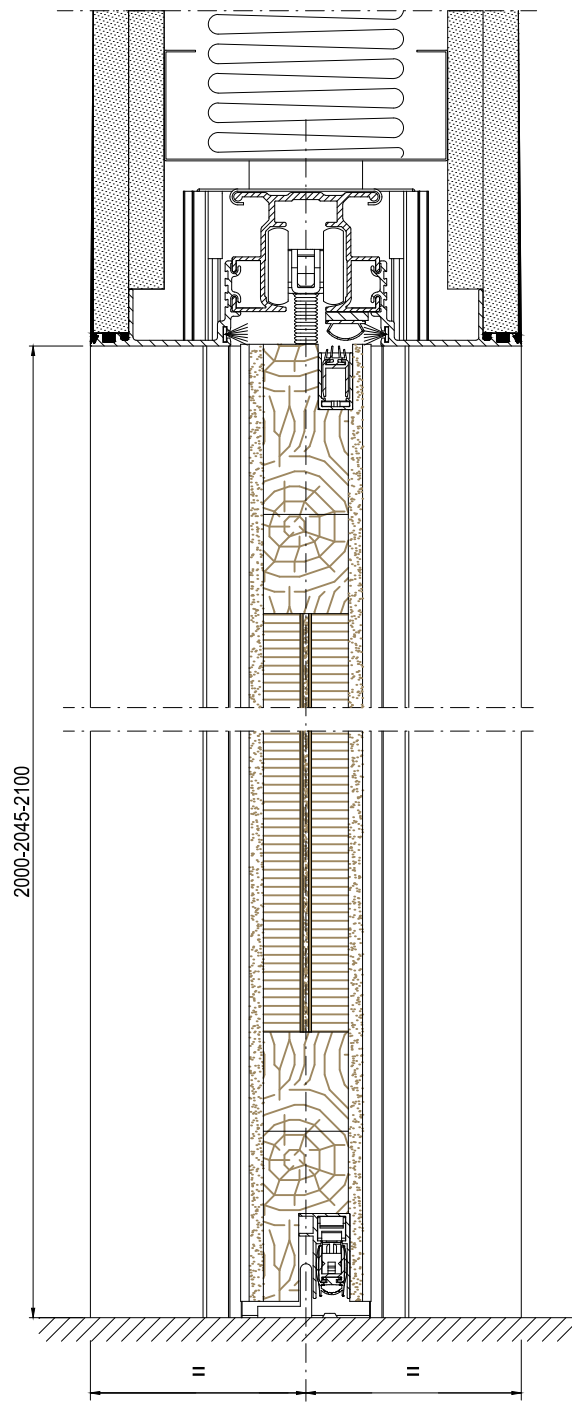

Sezione orizzontale 150 2L
porta chiusa
Section horizontale 150 2 D
porte fermée
Horizontal section two 150 Panels
closed door

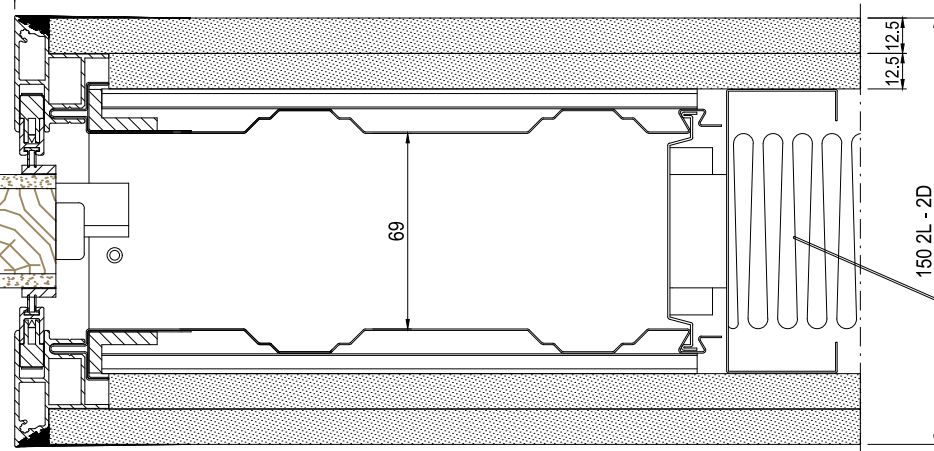

Costruzione flessibile standard. Parete in cartongesso a doppia lastra Sp.12,5 mm fissata a profili a U e C Sp.100 mm. Con Lana di vetro Sp. 70 densità 50 Kg/m³
Construction adaptable standard. Cloison en plaques de plâtre double dalle Ép.12,5 mm fixée à des profils en U et C Ép.100 mm. Avec laine de verre ép. 70 densité 50 kg/m³
Flexible standard construction. Plasterboard wall with double panel thickness 12.5 mm fixed to 100 mm thick U and C profiles. With 70 thickness fibreglass 50 kg/m³ density

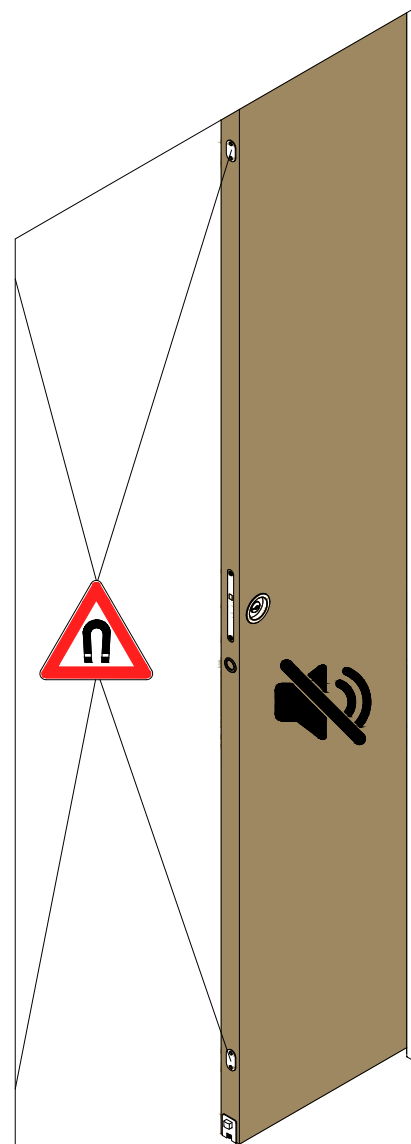

Articolo venduto separatamente
Artículo vendido por separado
Artikel separat erhältlich

ESSENTIAL
125 CARTONGESSO 1 LASTRA
150 CARTONGESSO 2 LASTRE

ESSENTIAL
125 CARTÓN-YESO 1 PLACA
150 CARTÓN-YESO 2 PLACAS

ESSENTIAL
125 TROCKENBAUWAND 1 PLATTE
150 TROCKENBAUWAND 2 PLATTEN

ANTA ACUSTICA HOJA ACÚSTICA AKUSTISCHER TÜRFLÜGEL

Articolo venduto separatamente
Artículo vendido por separado
Artikel separat erhältlich

LUCE COMMERCIALE	LUCE EFFETTIVA	ANTA
HUECO COMERCIAL	HUECO REAL	HOJA
LICHTE GESAMT	EFFEKTIVE LICHTE	TÜRFLÜGEL
L	L - 10	Lp = L + 15
600	590	615
700	690	715
800	790	815
900	890	915
1000	990	1015

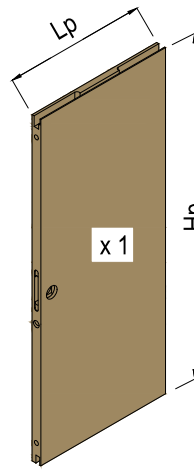

* VERIFICARE PRIMA DI ORDINARE LA PORTA
* VERIFICAR ANTES DE ENCARGAR LA PUERTA
 * VOR BESTELLUNG DER TÜR ÜBERPRÜFEN

LUCE HUECO LICHTE	ANTA HOJA TÜRFLÜGEL
H	Hp = H - 6
2000*	1994
2045*	2039
2100*	2094

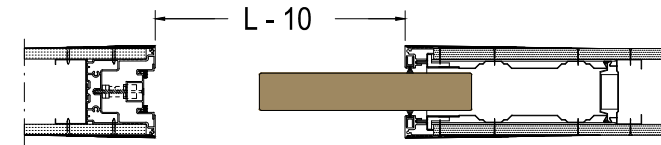
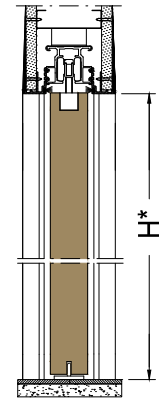

KIT FERRAMENTA - KIT HERRAJES - BESCHLAG-SET

Articolo venduto separatamente
Artículo vendido por separado
Artikel separat erhältlich

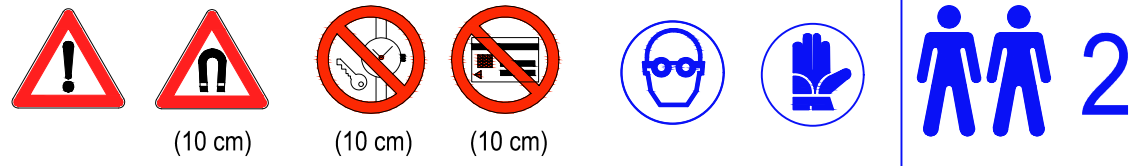
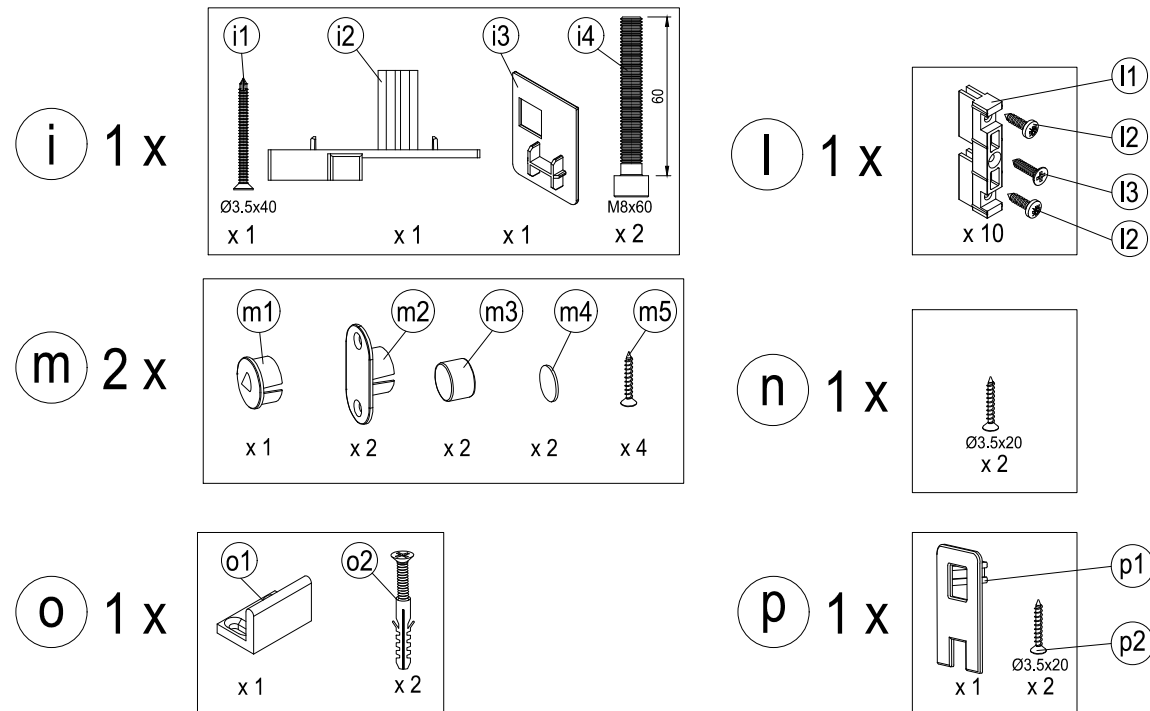
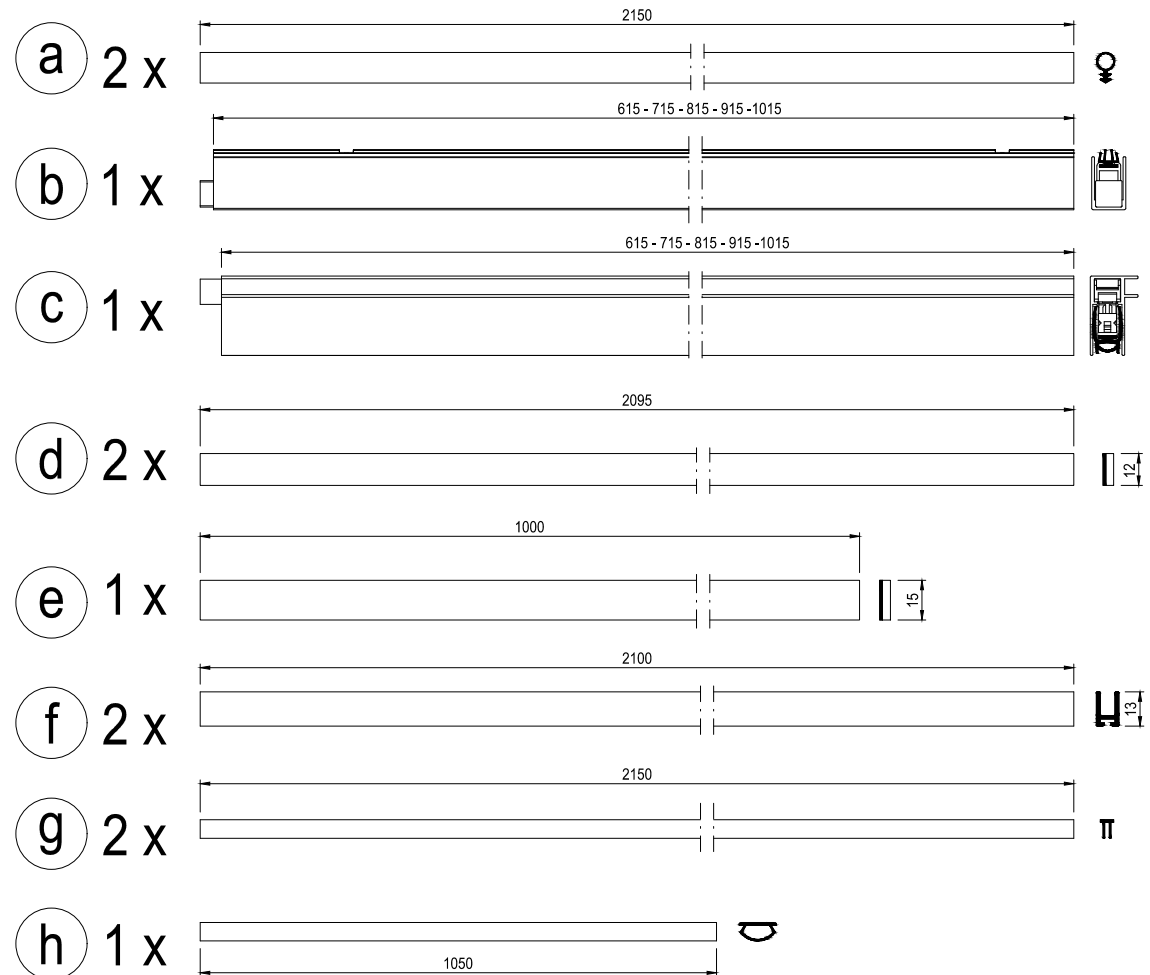

Nota: Test eseguito con telaio posato a regola d'arte, foro di passaggio 1000x2100 con kit chiudiscigno con serratura
Nota: ensayo realizado con marco perfectamente instalado, hueco de paso 1000x2100 con kit Chiu-discigno con cerradura
Hinweis: Test mit professionell montiertem Rahmen, Durchgangsbohrung 1000x2100 mit Set Chiu-discigno mit Schloss

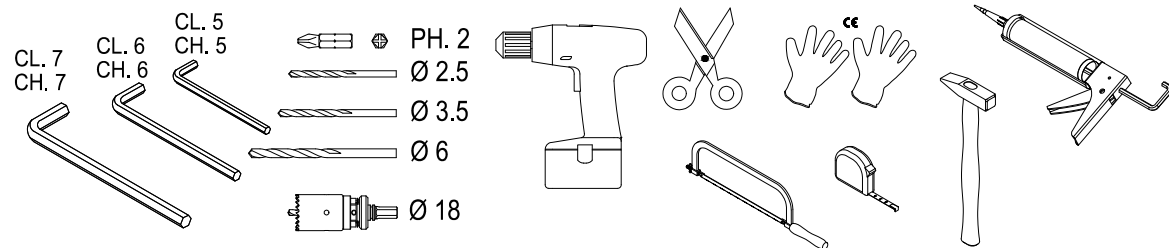

INSTALLAZIONE ANTA
 INSTALACIÓN DE LA HOJA
 MONTAGE TÜRFLÜGEL

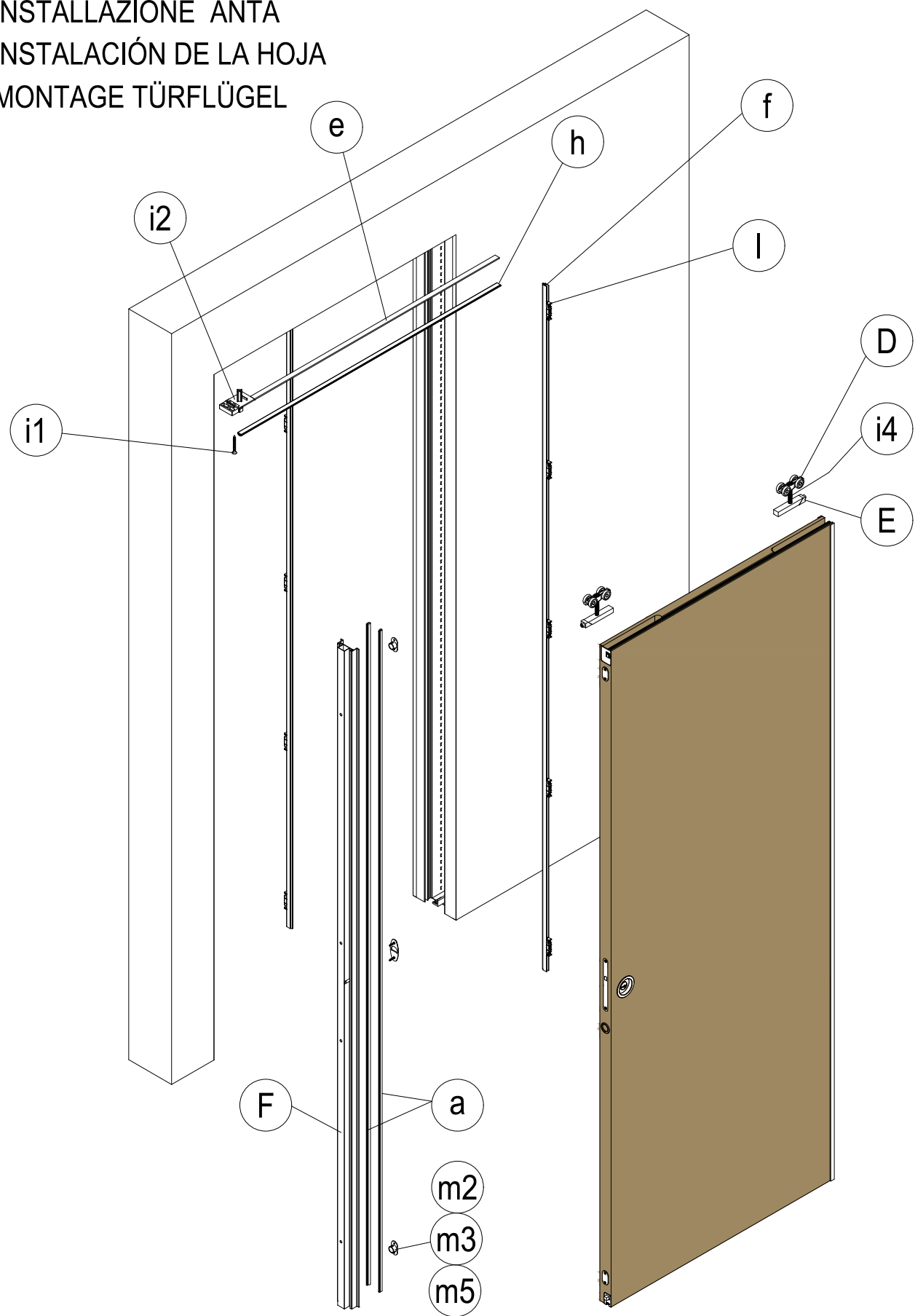

ACCESSORI DA PRELEVARE DALLA DOTAZIONE DEL CONTROTELAIO
 ACCESORIOS A UTILIZAR DE ENTRE LOS INCLUIDOS CON EL PREMARCO
 AUS DEM LIEFERUMFANG DES EINBAUELEMENTS ZU ENTNEHMENDES ZUBEHÖR

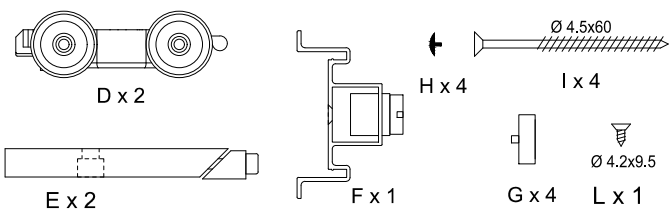

ACCESSORI NON NECESSARI
 ACCESORIOS NO NECESARIOS
 NICHT ERFORDERLICHES ZUBEHÖR

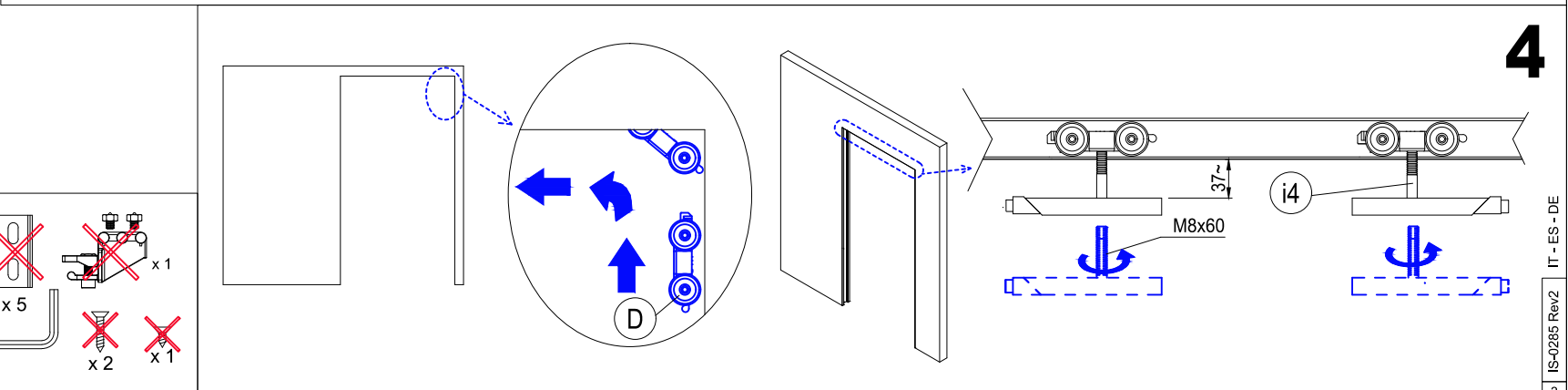
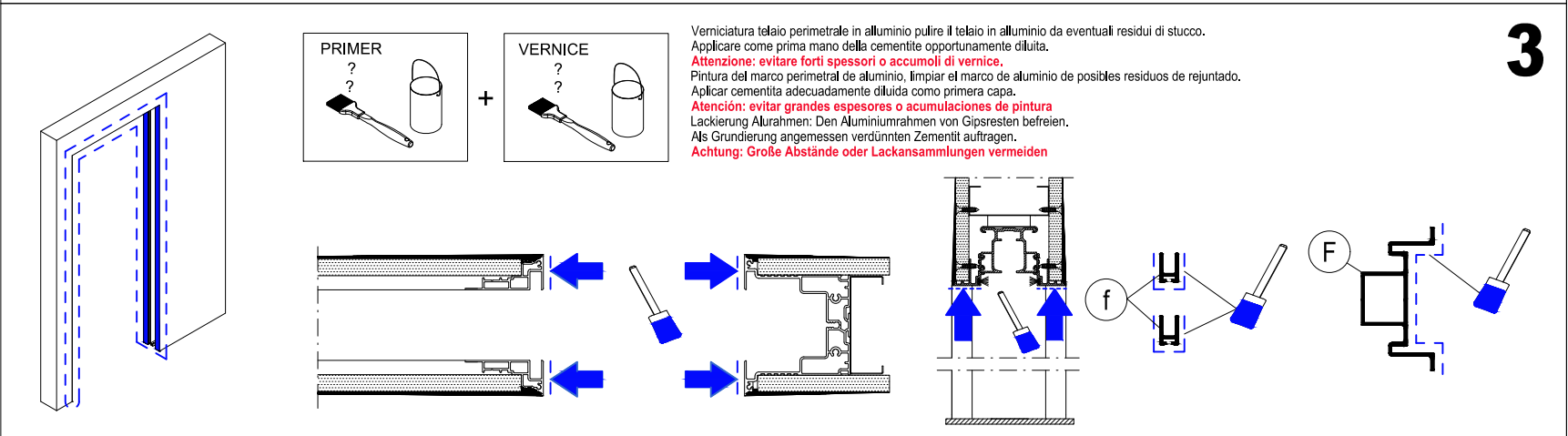
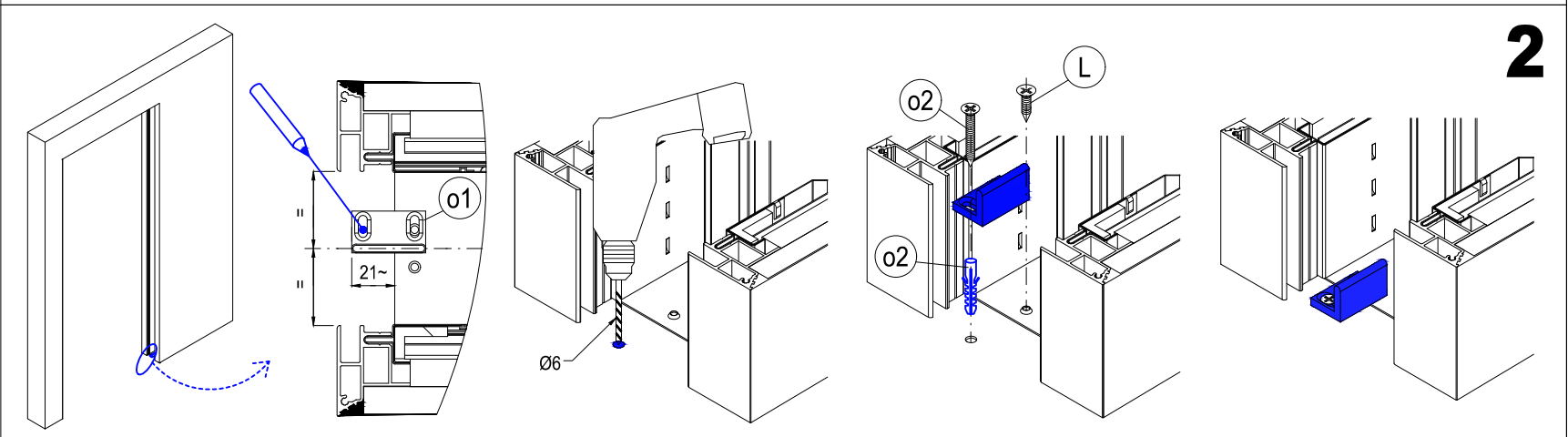
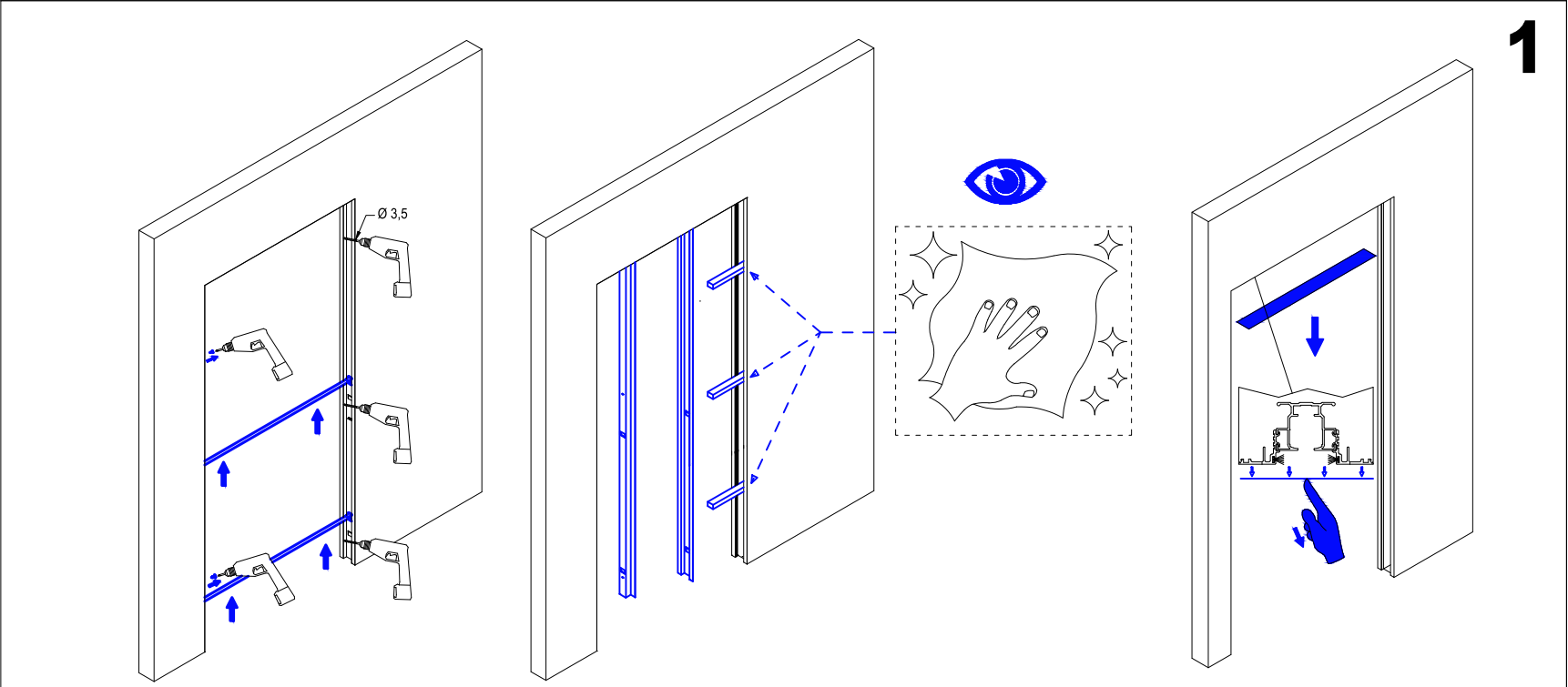
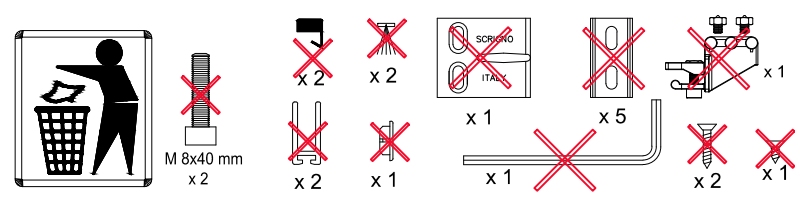

1

2

3

4

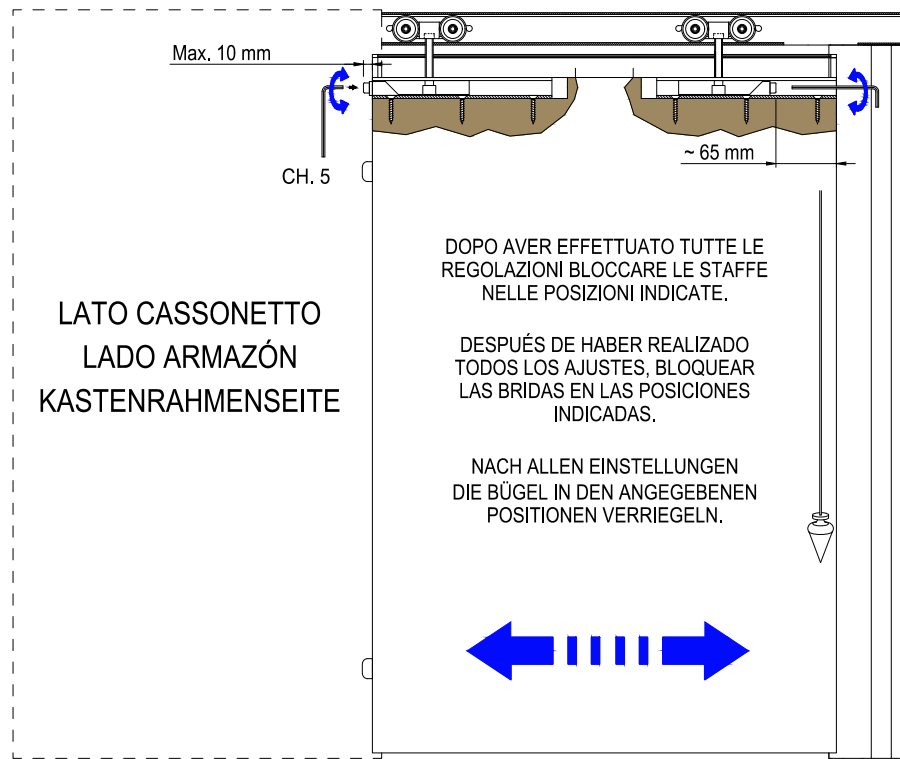
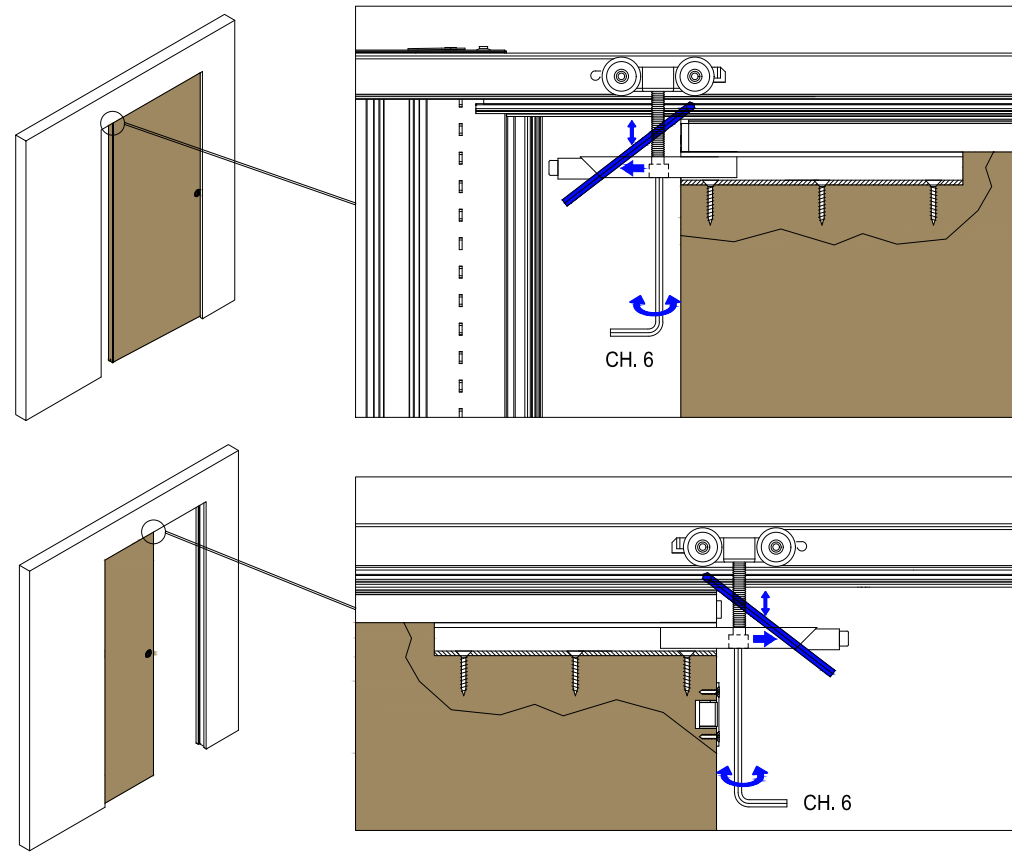

5

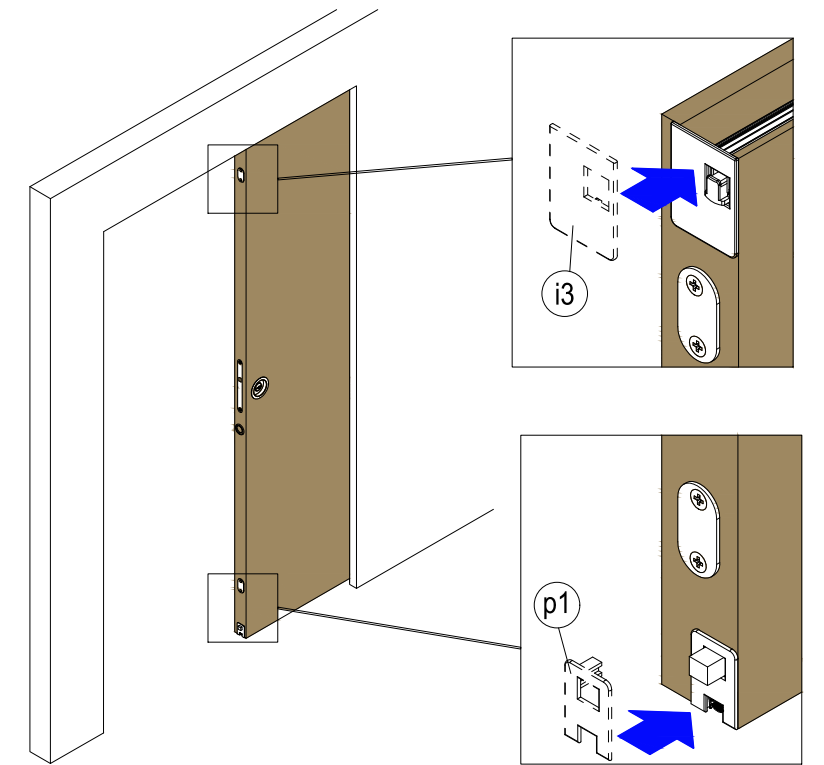

6

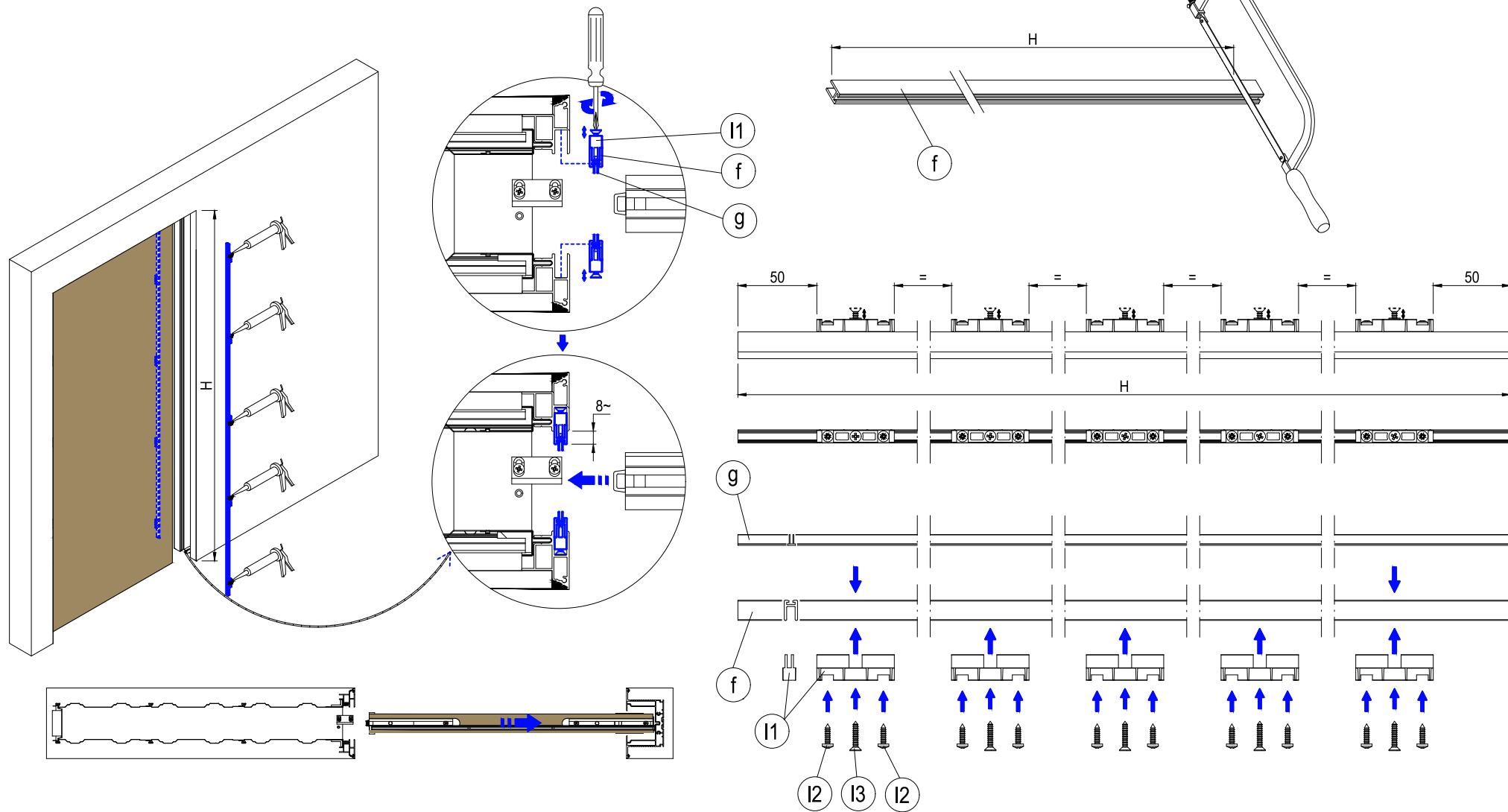

7

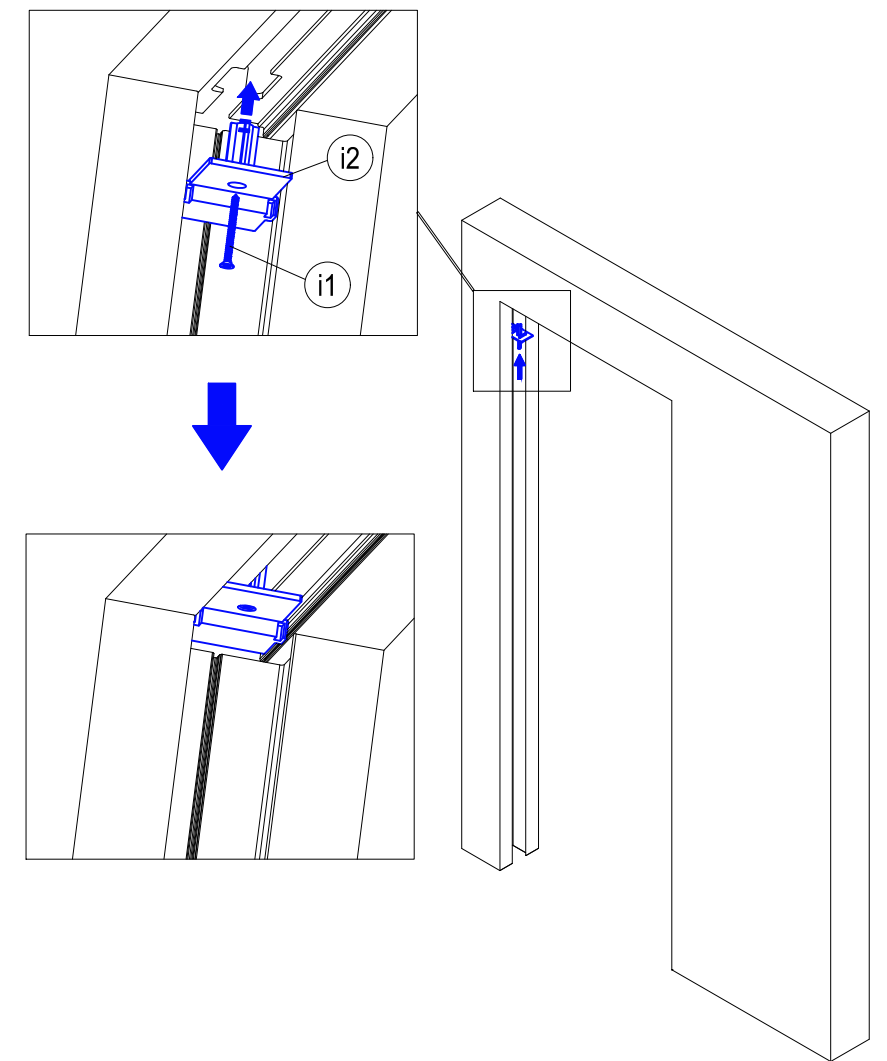

8

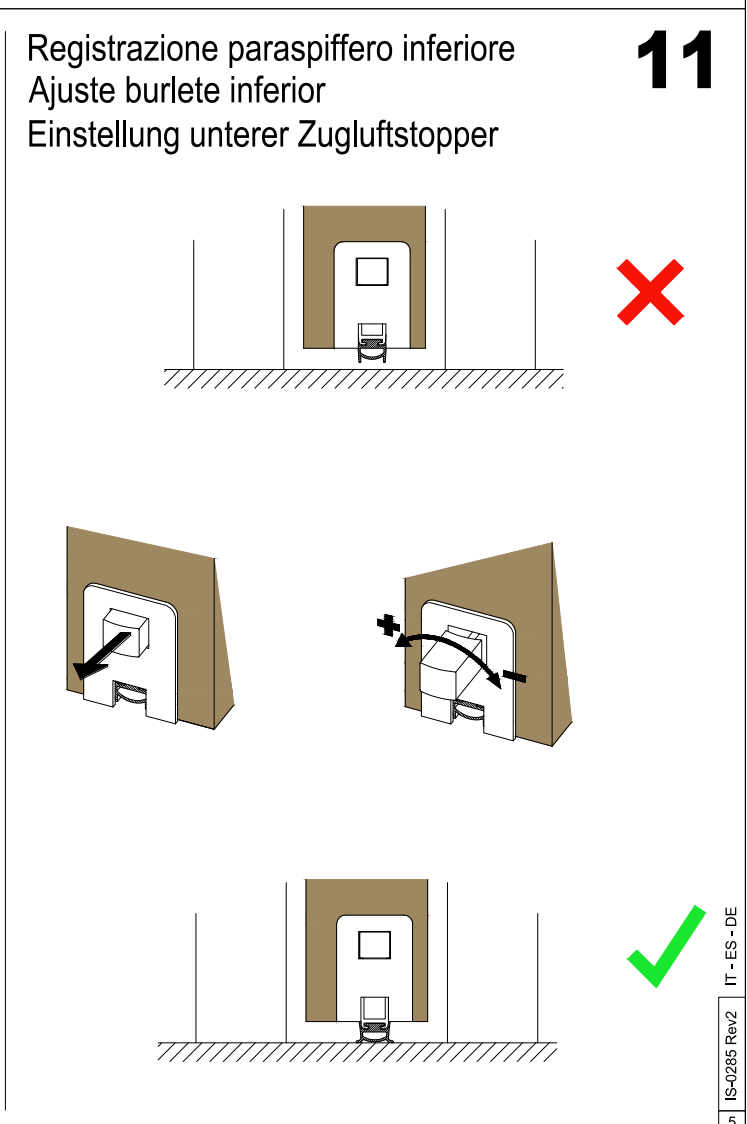
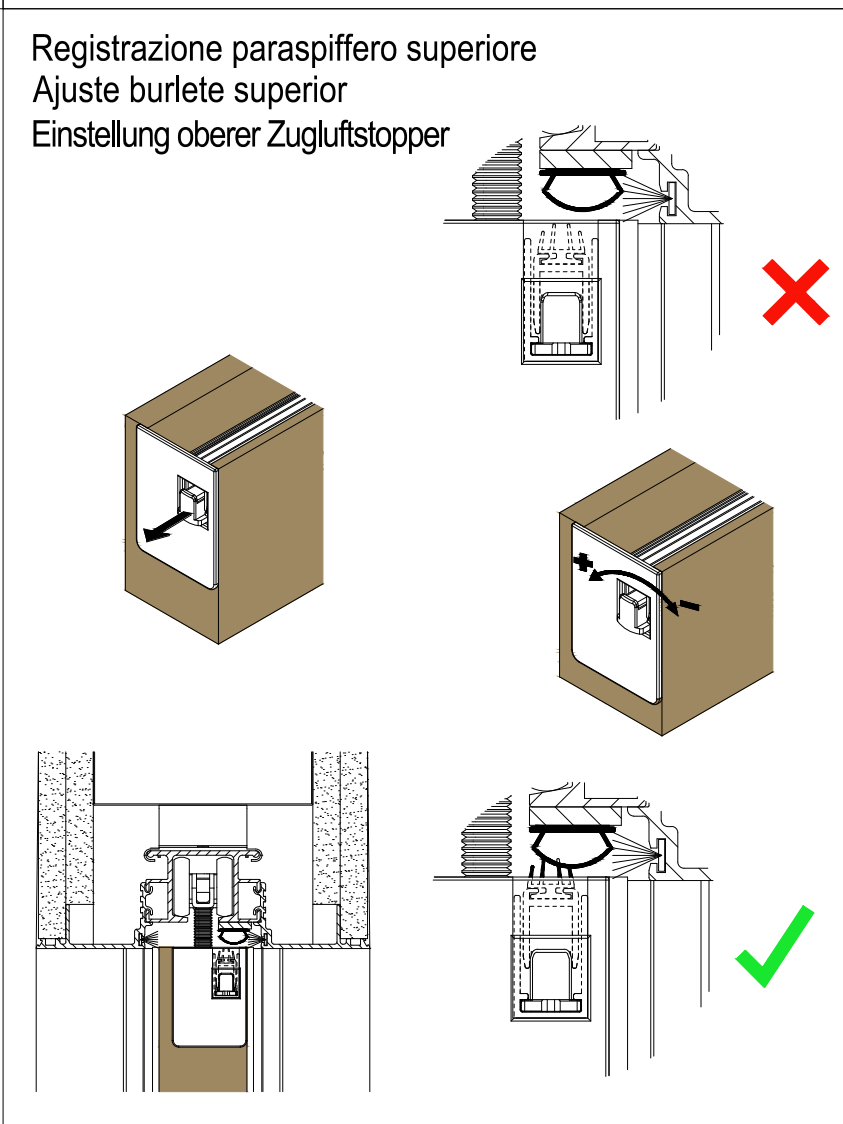
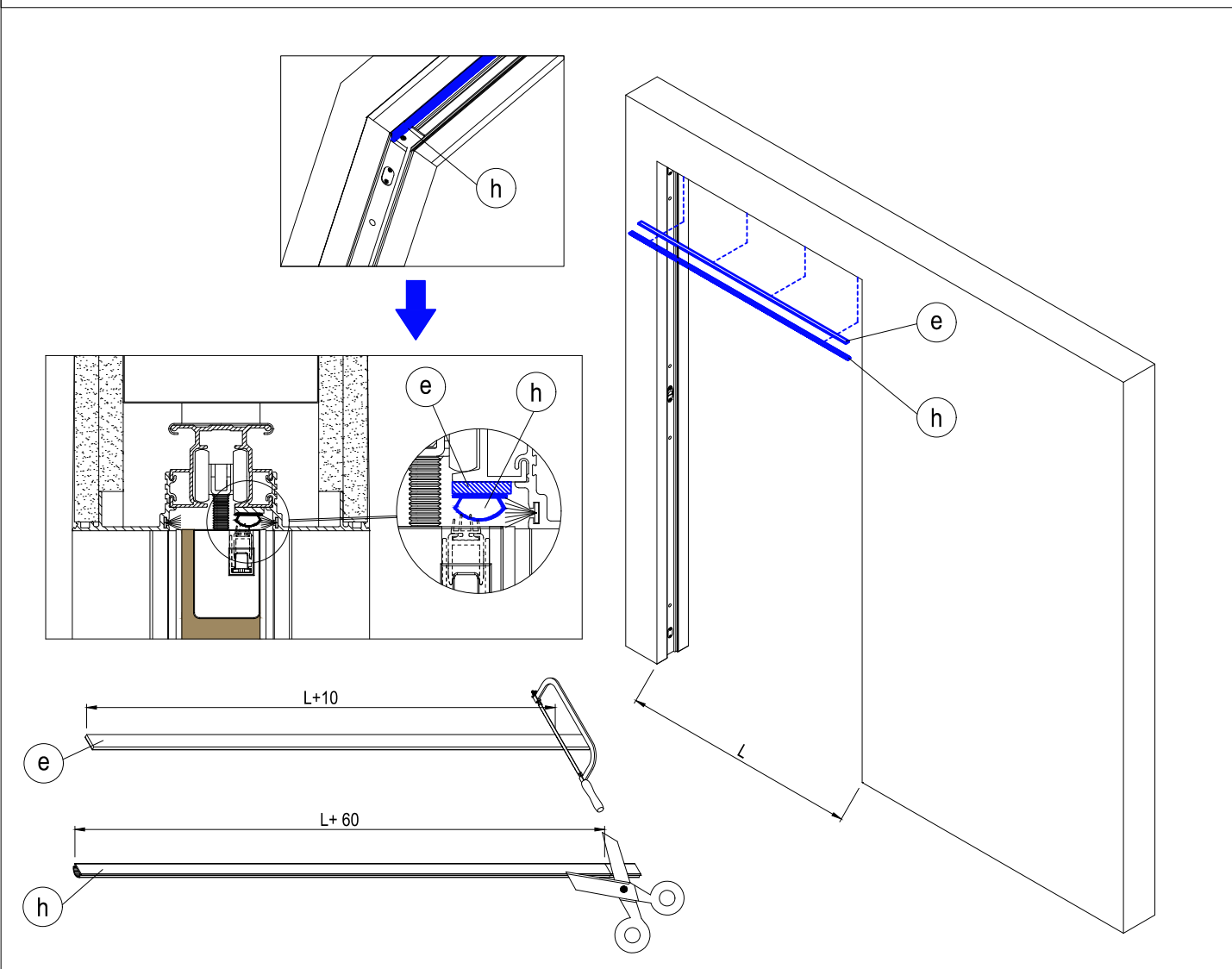
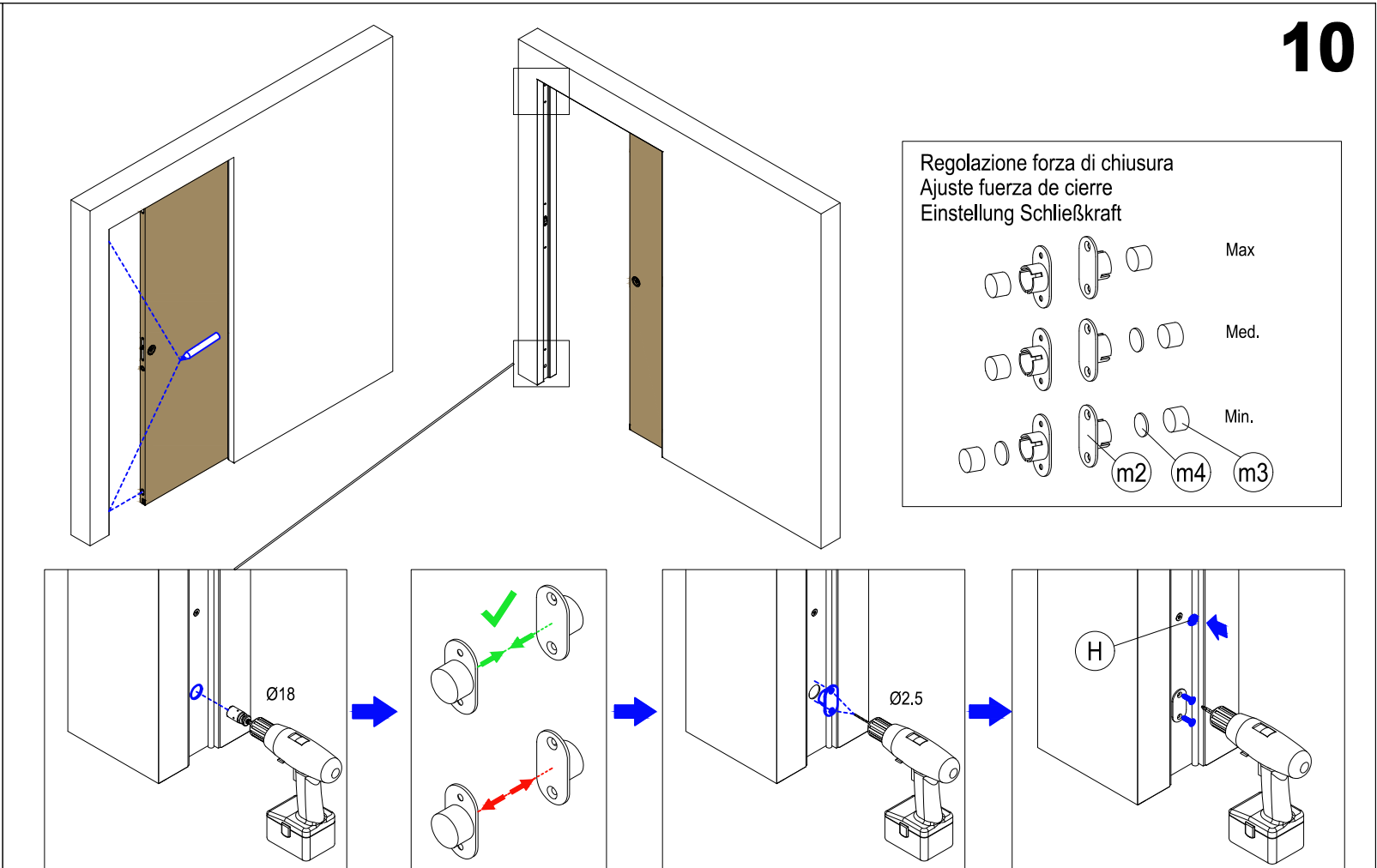
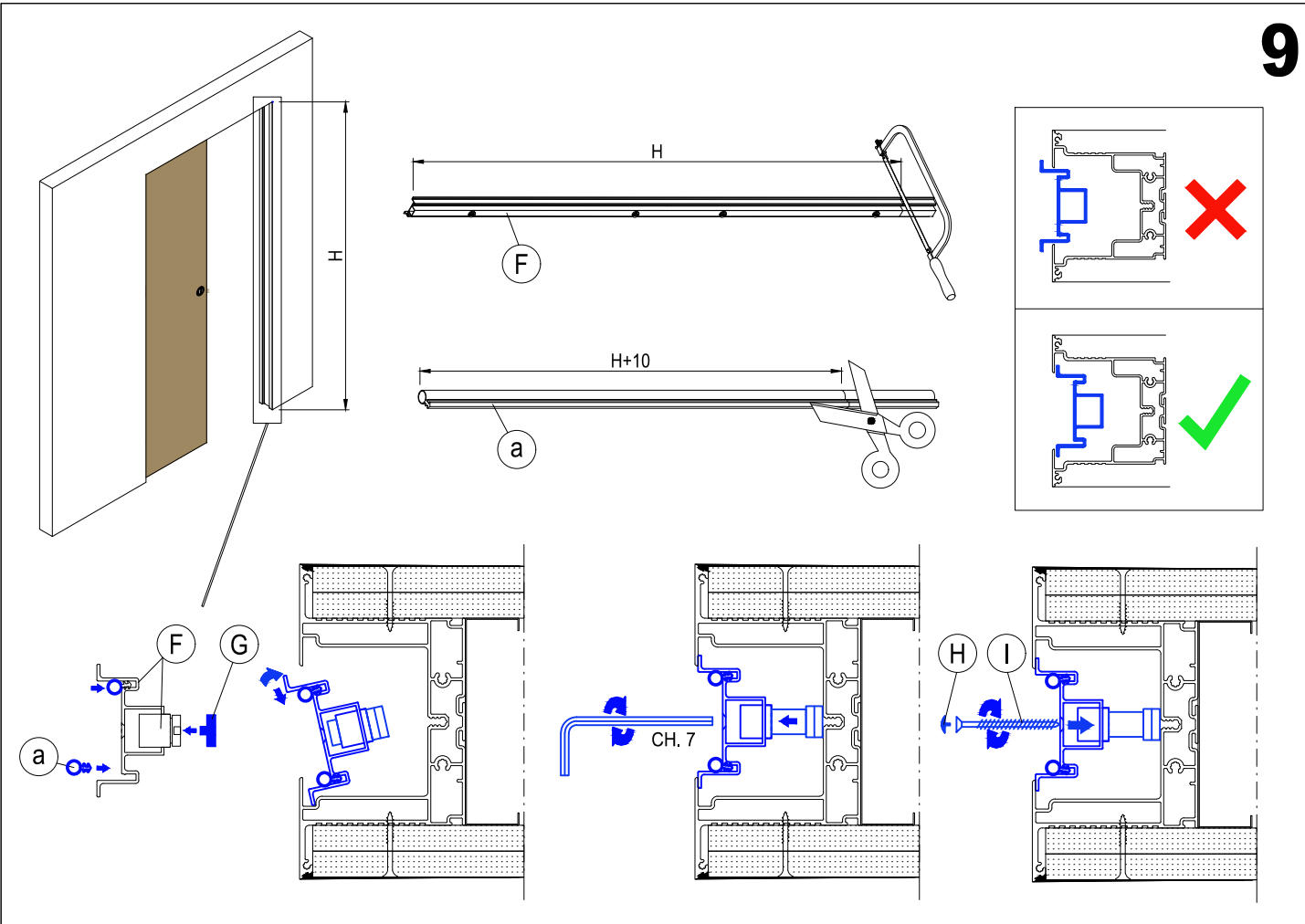

Luce commerciale 600-700-800-900-1000
 Luce effettiva 590-690-790-890-990
 Hueco comercial 600-700-800-900-1000
 Hueco real 590-690-790-890-990
 Lichte gesamt 600-700-800-900-1000
 Effektive Lichte 590-690-790-890-990

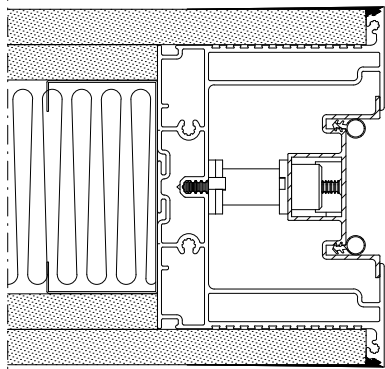

A
 A

Sezione orizzontale 125 1L
 porta aperta

Sección horizontal 125 1L
 puerta abierta

Horizontaler Querschnitt 125 1L
 Tür geöffnet

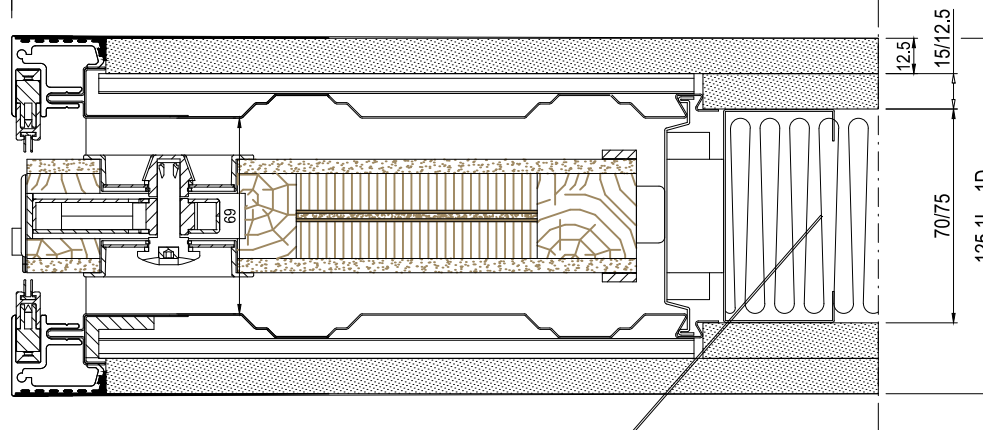

Costruzione flessibile standard. Parete in cartongesso a doppia lastra Sp.12,5 mm fissata a profili a U e C Sp.75 mm. Con Lana di vetro Sp. 70 densità 50 Kg/m³
 Construcción flexible estándar. Pared de cartón-yeso de doble placa Esp.12,5 mm fijada a perfiles en U y C Esp.75 mm. Con lana de vidrio Esp. 70 densidad 50 kg/m³
 Flexible Standardkonstruktion. Trockenbauwand mit doppelter Platte, Stärke 12,5 mm, befestigt an U- und C-Profilen, Stärke 75 mm. Mit Glaswolle, Stärke 70, Dichte 50 Kg/m³

Sezione A-A (125 1L)

Sección A-A (125 1L)

Querschnitt A-A (125 1L)

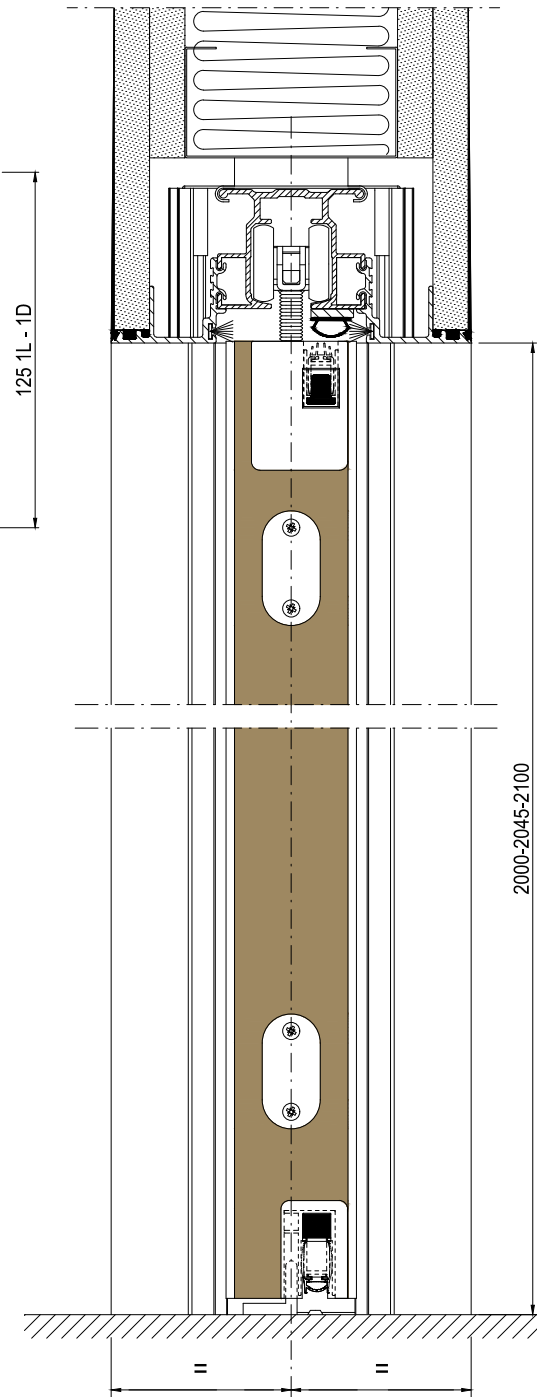

Sezione B-B (150 2L)

Sección B-B (150 2L)

Querschnitt B-B (150 2L)

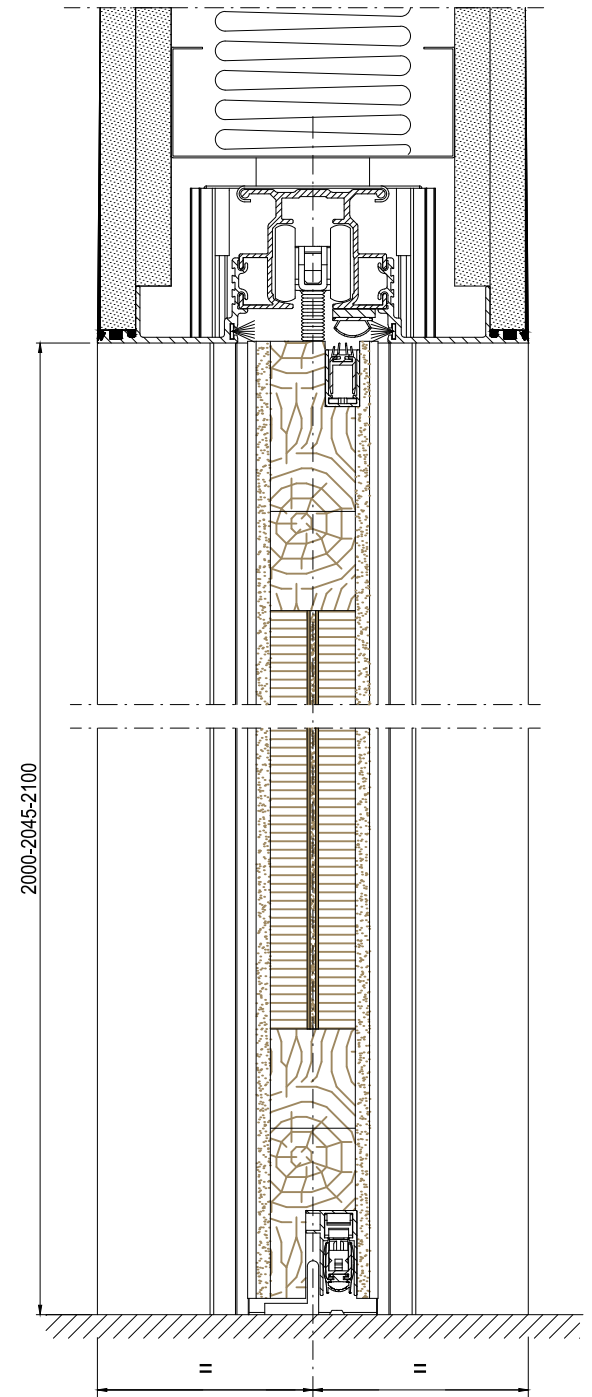

Luce commerciale 600-700-800-900-1000
 Luce effettiva 590-690-790-890-990
 Hueco comercial 600-700-800-900-1000
 Hueco real 590-690-790-890-990
 Lichte gesamt 600-700-800-900-1000
 Effektive Lichte 590-690-790-890-990

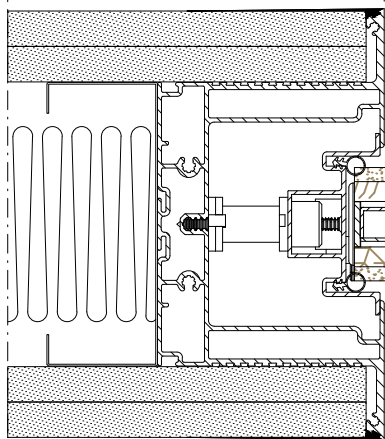

B
 B

Sezione orizzontale 150 2L
 porta chiusa

Sección horizontal 150 2L
 puerta cerrada

Horizontaler Querschnitt 150 2L
 Tür geschlossen

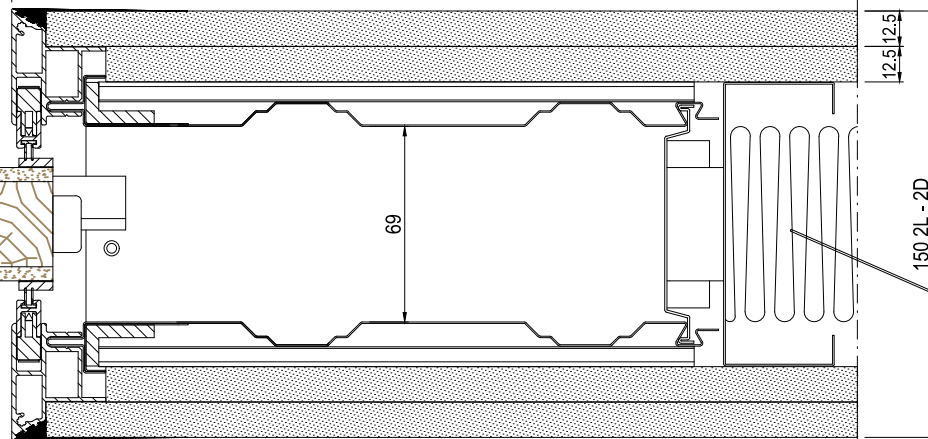

Costruzione flessibile standard. Parete in cartongesso a doppia lastra Sp.12,5 mm fissata a profili a U e C Sp.100 mm. Con Lana di vetro Sp. 70 densità 50 Kg/m³
 Construcción flexible estándar. Pared de cartón-yeso de doble placa Esp.12,5 mm fijada a perfiles en U y C Esp.100 mm. Con lana de vidrio Esp. 70 densidad 50 kg/m³
 Flexible Standardkonstruktion. Trockenbauwand mit doppelter Platte, Stärke 12,5 mm, befestigt an U- und C-Profilen, Stärke 100 mm. Mit Glaswolle, Stärke 70, Dichte 50 Kg/m³