

# XTERNA - SOFT 30

KIT PINZE PER PORTE TOTALMENTE IN VETRO  
 KIT DE PINCES POUR PORTES ENTIEREMENT EN VERRE  
 KIT OF CLAMPS FOR FULL GLASS DOORS  
 KIT PINZAS PARA PUERTAS TOTALMENTE DE VIDRIO

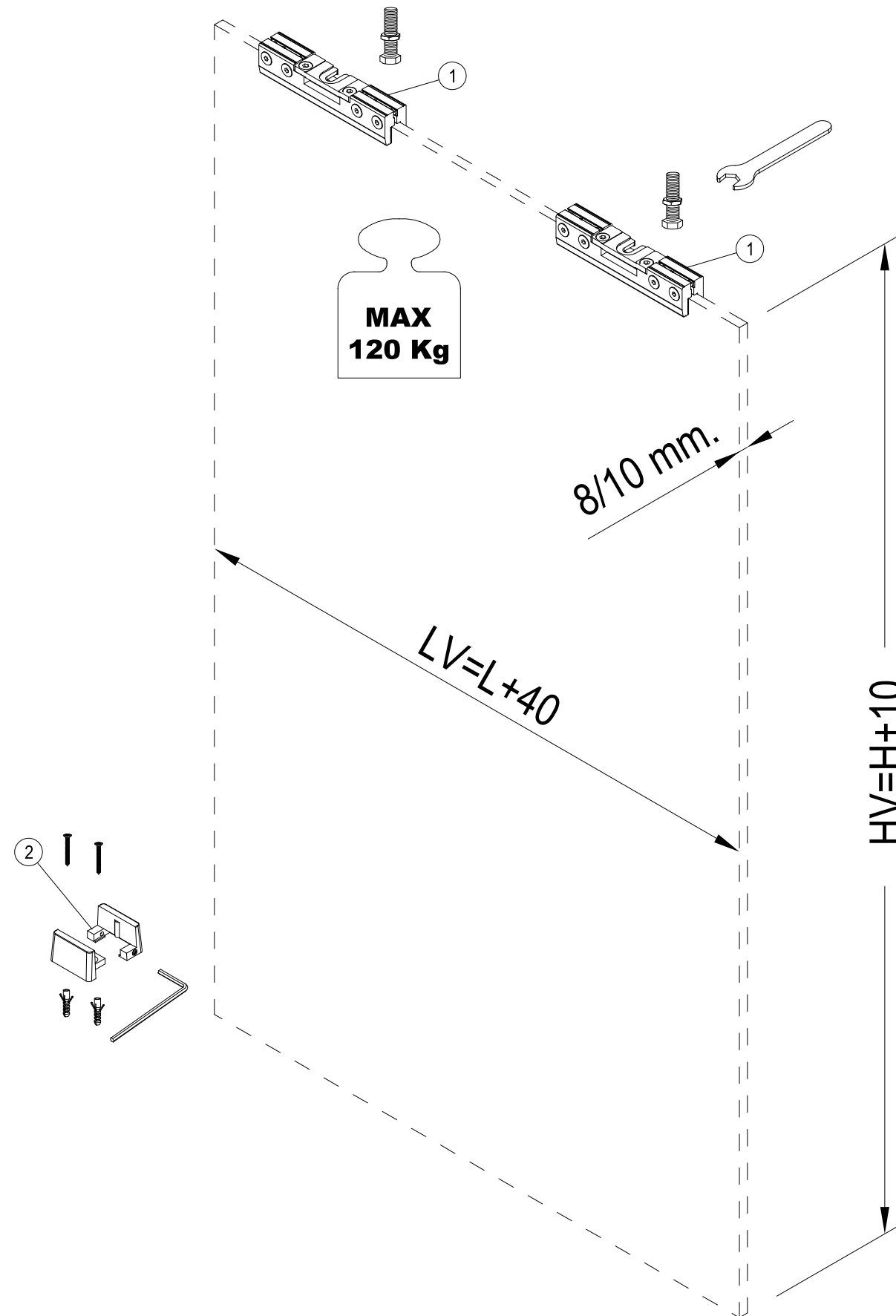

Contenuto confezione - Contenu de l'emballage - Box contents - Contenido caja

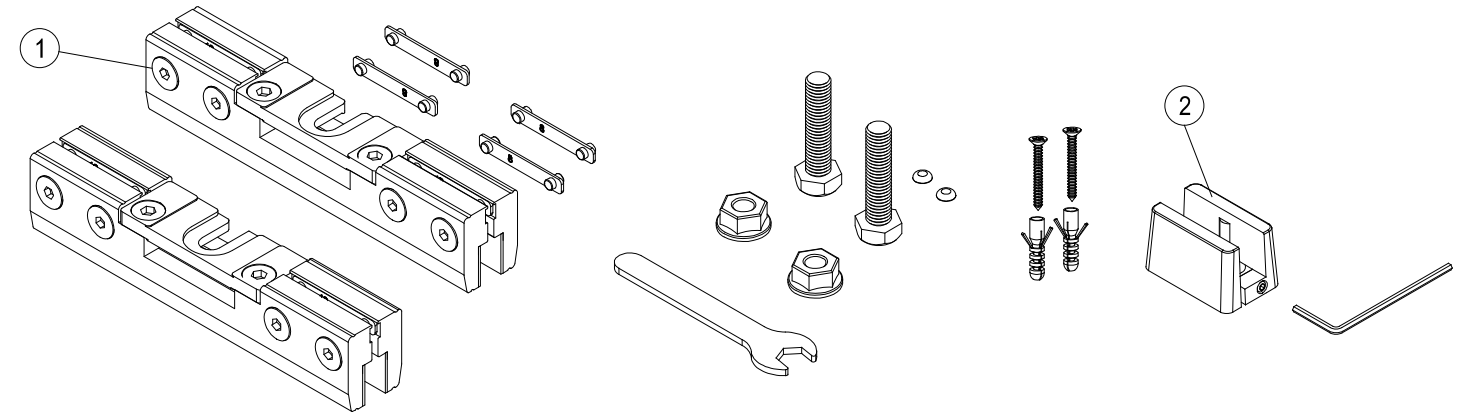

Cambio spessore vetro - Changement de l'épaisseur - Changing glass thickness - Cambio grosor vidrio

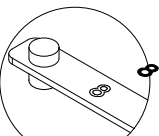
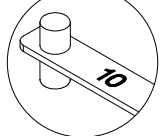
		Sostituire gli spessori	Replace spacers
VETRO 8 mm. VERRE 8 mm.	GLASS 8 mm VIDRIO 8 mm	Remplacer les cales	Cambiar los grosores
VETRO 10 mm. VERRE 10 mm.	GLASS 10 mm VIDRIO 10 mm		

Il numero che indica lo spessore del vetro DEVE stare a vista  
 Le numéro indiquant l'épaisseur du verre DOIT rester visible  
 The number indicating the glass thickness MUST remain visible  
 El número que indica el grosor del vidrio TIENE QUE verse claramente

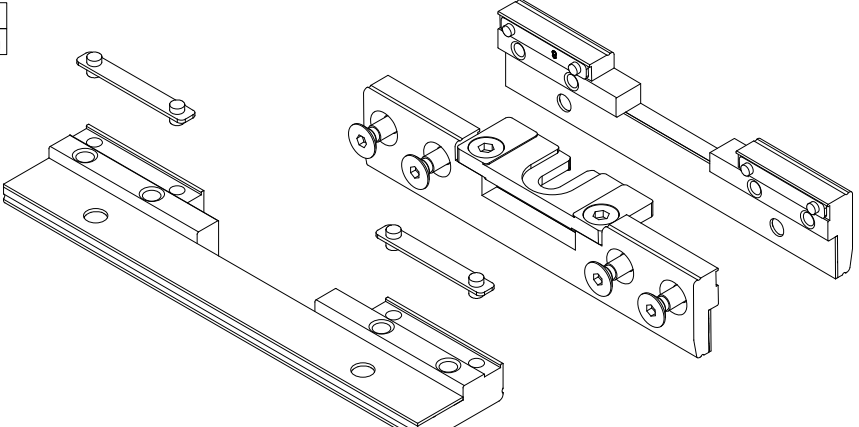
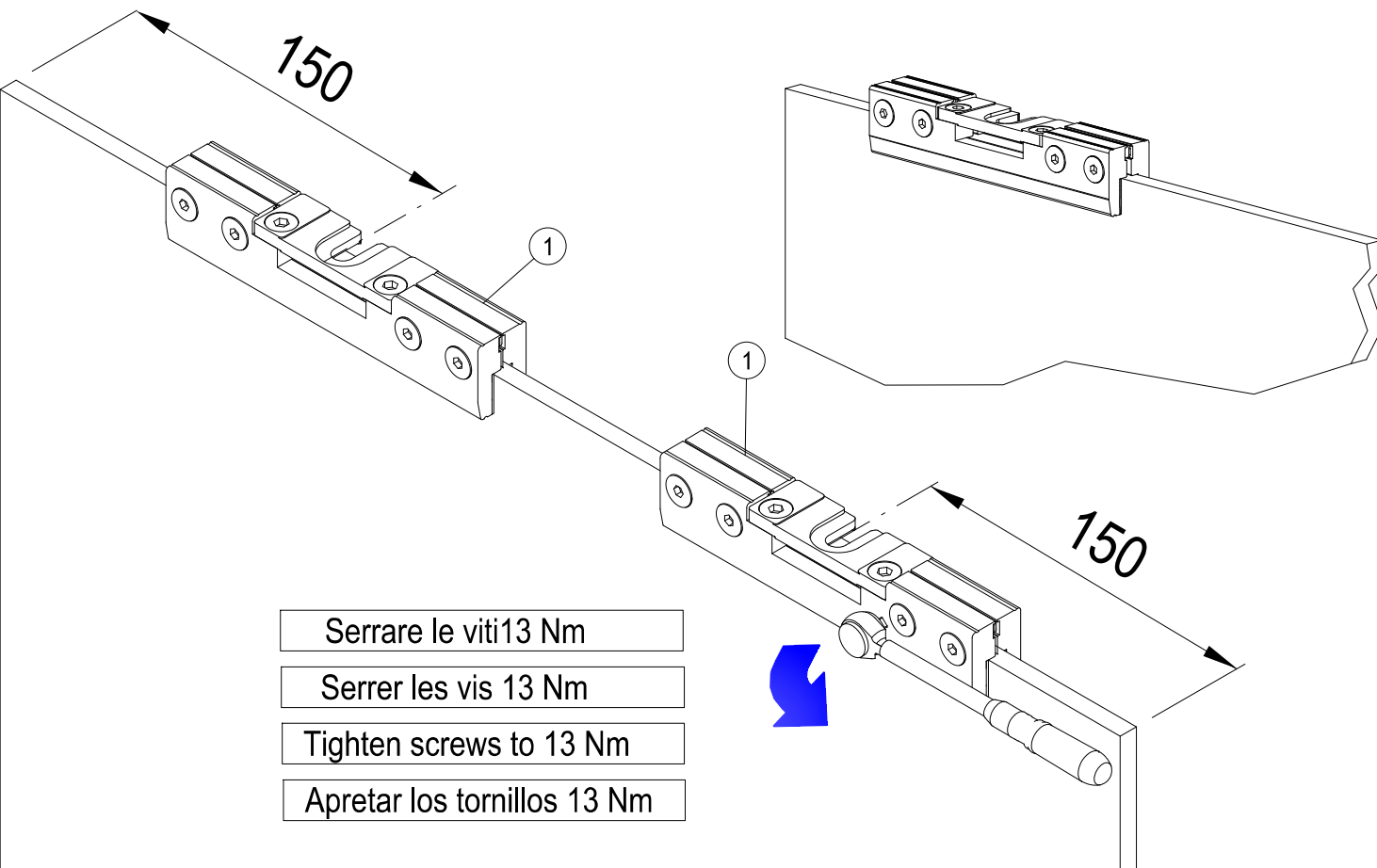
150

1

150

Serrare le viti 13 Nm  
 Serrer les vis 13 Nm  
 Tighten screws to 13 Nm  
 Apretar los tornillos 13 Nm

